



Battery Checker BR-3000

Thank you for purchasing a BR-3000.
The BR-3000 can check the state of various battery packs used as the power source of R/C receivers, etc. Battery pack total voltage display and remaining capacity (criteria) are displayed on a bar graph and in %. The voltage of each cell of a lithium battery pack can also be displayed.
To sufficiently display its performance and for safe use, please read this manual before using the BR-3000.

Instruction Manual

CAUTION

▲ The BR-3000 Battery Checker can only be used with the battery packs shown in "Corresponding Battery Packs" below. It cannot handle batteries of other cell sizes and types. The checker display is based on voltage. Since the voltage changes with the battery itself and the ambient temperature, use the remaining capacity display as a criteria only.

Corresponding Battery Packs:

● Lithium ferrite Li-Fe (2~7 cells) ● Lithium polymer Li-Po (2~7 cells) ● Lithium ion Li-Ion (2~7 cells) ● Nickel cadmium Ni-Cd (4~7 cells) ● Nickel metal hydride Ni-MH (4~7 cell)

Functions of the BR-3000

The display functions of the BR-3000 are shown below. However, the functions that can be displayed vary depending on the type of battery pack.

*The BR-3000 operates on the power supplied from the connected battery.

[Display Functions]	Li-Fe/Li-Po/Li-Ion	Ni-Cd/Ni-MH	(X: Yes, ---: No)
Total voltage	X	X	
Remaining capacity (criteria)	X	X	Bar graph, % display
Cell voltage	X	---	Each cell
Minimum cell voltage	X	---	
Maximum cell voltage	X	---	
Cell voltage difference	X	---	Maximum-minimum

[BR-3000 Ratings]

(Specifications and ratings are subject to change without notice.)

- Applicable battery packs: (See the above.)
- Voltage display error: ±1.5%
- Display range
- Total voltage: (Ni type) 4.0~17V, (Li type) 5~34V
- Cell voltage: (Li type) 1.1~4.9V
- Case size: 85x63x15mm (excluding projecting parts)
- Weight: 52.6g
- Operating temperature: -10~+45°C
- Storage temperature: -20~+60°C

Usage Precautions

Special Markings;

Pay special attention to the safety at the parts of this manual that are indicated by the following marks.

Symbol:

- ⊘ ; Prohibited
- ⚠ ; Mandatory

Mark	Meaning
⚠ DANGER	Procedures which may lead to a dangerous condition and cause death or serious injury to the user if not carried out properly.
⚠ WARNING	Procedures which may lead to a dangerous condition or cause death or serious injury to the user if not carried out properly, or procedures where the probability of superficial injury or physical damage is high.
⚠ CAUTION	Procedures where the possibility of serious injury to the user is small, but there is a danger of injury, or physical damage, if not carried out properly.

WARNING

- ⊘ Do not use the BR-3000 near objects that may ignite.
- Ignition by sparking when the battery is connected and disconnected is extremely dangerous.

- ⊘ Do not connect a battery pack to the 2 connectors at the same time.
- The battery may short circuit and cause abnormal heating and sparking.

CAUTION

- ⊘ Never connect the battery in reverse.
- Reverse connection may damage the inside of the BR-3000.
- ⊘ Never get the BR-3000 wet.
- The BR-3000 houses precision electronic circuits which may malfunction if water or other solution enters the case. If the BR-3000 should get wet, always send it for repair.
- ⊘ Do not use the BR-3000 by placing it on a combustible material.
- There is the danger of abnormal heating of the battery for some reason.
- ⊘ Do not store the BR-3000 within the reach of children.
- ⚠ Be careful not to cause a short circuit by pinching the cord of the battery pack.
- Shorting may cause abnormal heating or sparking of the battery.

<Battery Pack Care>

For safety and to extract maximum performance from the battery pack used, observe the following points:

- Discharge and store the battery pack in accordance with the battery instruction manual.
- Do not discharge a battery more than 80%. (Remaining capacity no less than 20%)
- Use the specified charger to charge the battery pack.

<When requesting repair>

Before requesting repair, read this instruction manual again and check the BR-3000. When there is an abnormality, request repair to your local Futaba dealer.

Name of Each Part/Connection Method

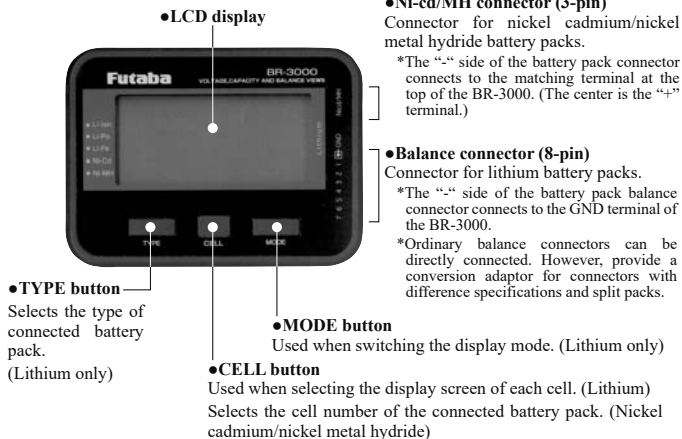

Usage Method

[Lithium battery pack]

The total voltage, remaining capacity (criteria), cell voltage, minimum cell voltage, maximum cell voltage, and cell voltage difference of lithium battery packs can be checked by the following method:

- 1 Connect the battery pack to the 8-pin connector.
- 2 Select the type of battery pack with the TYPE button. (LiPo→LiFe→LiIon)

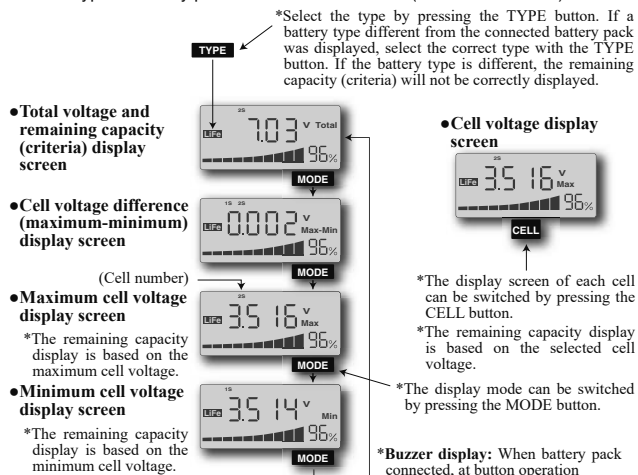

<Balance operation (lithium only)>

Balance operation automatically starts about 5 seconds after the battery is connected. When the voltage difference between cells reaches 5mV or less, balance operation ends and then the BR-3000 enters the sleep mode and "----" appears on the screen.

- *The sleep mode can be exited by button operation.
- *When the balance operation continues even if about 30 minutes pass, confirm the voltage of each cell. An internal cell might be defective.

[Nickel cadmium/nickel metal hydride battery pack]

The total voltage and remaining capacity (criteria) of nickel cadmium and nickel metal hydride battery packs can be checked by the following method. However, each cell CANNOT be displayed.

- 1 Connect the battery pack to the 3-pin connector.
- 2 Select the cell number by pressing the CELL button matched to the connected battery pack.

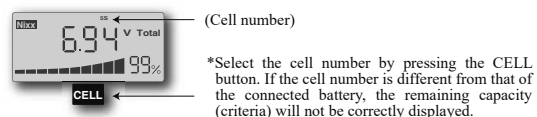

Remaining capacity display

*The remaining capacity (criteria) display is based on voltage at no load. Since it may differ largely from actual remaining capacity according to the battery type, use it as a criteria only.

*From the standpoint of the battery characteristics, immediately after charging and discharging, the remaining capacity display will change until the battery stabilizes. The voltage stabilizes about 30 minutes after charging and discharging.

In addition, because of the different discharge characteristics, when the specified capacity was checked after use, a remaining capacity lower than the actual remaining capacity may be displayed even for the same type of battery. Judge the remaining capacity with the stable state value as a criteria.

*When the remaining capacity (criteria) display reaches 20% or less, recharge the battery.

*When the remaining capacity (criteria) display exceeds 95%, since the battery is almost fully charged, refrain from charging it. Overcharging will cause the battery to deteriorate.

Battery Checker BR-3000 Connecting the Battery

BR-3000 does not have a power switch. The BR-3000 operates on the power supplied from the connected battery.

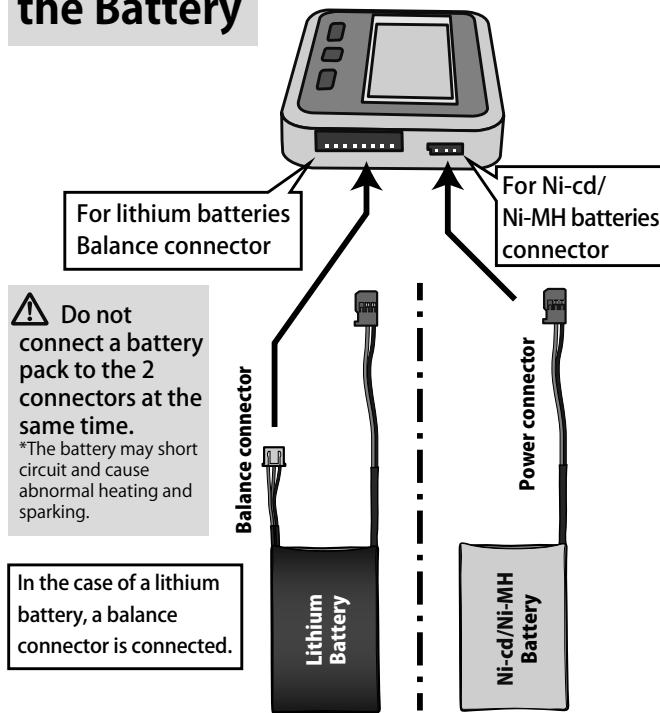

Notes :

- This is not a manual. There is a manual independently.
- Before using your BR-3000, please read another manual thoroughly and use the BR-3000 properly and safely. After reading another manual, store it in a safe place.

Ni-cd/Ni-MH batteries connection

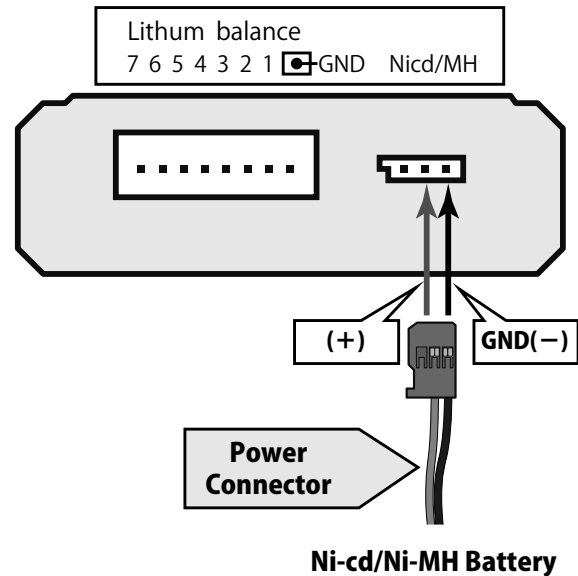

2cells Lithium batteries connection

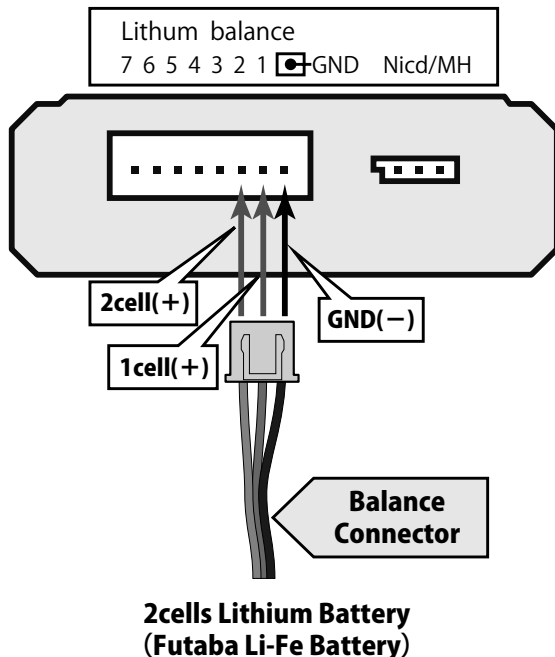

7cells Lithium batteries connection

