

Before using your new gyro, please read this manual thoroughly and use the gyro properly and safely. After reading this manual, store it in a safe place.

- No part of this manual may be reproduced in any form without prior permission.
- The contents of this manual are subject to change without prior notice.
- Futaba is not liable for any potential damage (accidental or otherwise) that may occur after installation.

### Features of GYC440

#### ● Dedicated RC car setting

Vehicle straightness and cornering performance can be increased without taking into account the effect of the road surface, etc.

#### ● Remote gain function and mode switching function

You can adjust gain from the transmitter (3 or more CH) by using the remote gain function. Gain can also be adjusted with the trimmer on the GYC440. The mode switching function allows AVCS/NORMAL gyro mode switching.

#### ● Integrated, compact, and light weight

Compact size (20.5x20.5x11mm) and light weight (3.7g) realized by high density mounting technology.

#### ● Easy setup

The GYC440 can be used immediately with minimum setup.

#### ● Supporting the S.BUS/S.BUS2 connection

Only one wire connection to the receiver can operate the GYC440.

### Functions

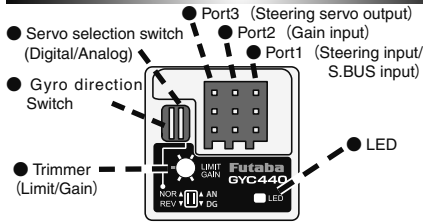

### Monitor LED display

State	Color	Move	Reference
1. No servo pulse / sensor error	Red	2 flash	
2. Warm-up	Green	Fast blink	
3. Sensor initialization	Red/Green	ON	AVCS (Red) NORMAL (Green)
4. Turn	Red/Green	Fast blink	Right (Green) Left (Red)
5. Neutral offset	Orange	Slow blink	Stick operation
6. Gain OFF	-	OFF	
7. Switch operation	Green	One blink	Each time of switch operation
8. Low battery	Red	One flash	Less than 4.0V

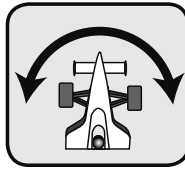

Thank you for purchasing the GYC440 RC cars gyro. Compact and lightweight, the GYC440 is designed to RC cars steering control. If the transmitter has 3 or more channels (capable of 3CH adjustment) the gyro sensitivity can be adjusted from the transmitter. Features include simple set-up and S.BUS/S.BUS2 connectivity.

### GYC440 Ratings:

(Integrated sensor type rate gyro)

- Gyro sensor: MEMS vibrating structure gyro
- Operating voltage: DC4.2V to 8.4V
- Current drain: 30mA (excluding a servo)
- Operating temperature range: -10°C to +45°C
- Dimensions: 20.5 x 20.5 x 11.0mm (except protrusion)
- Weight: 3.7g
- Functions: Sensitivity trimmer. LED monitor. Servo selection(Digital/Analog). S.BUS/S.BUS2 connection.

### Set Contents

The following items are supplied with the GYC440:

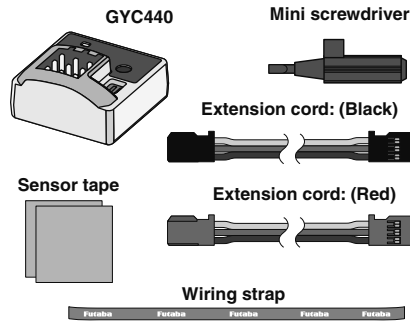

### ⚠WARNING

Failure to follow these safety precautions may result in severe injury to yourself and others.

#### ❗ Check that there is sufficient transmitter battery capacity.

❗ Analog servos cannot be used while in "digital servo" mode.

• Analog servos may break down if "digital servo" mode is selected.

❗ Do not operate the model and transmitter steering wheel for about 3-5 seconds after turning on the GYC440 (When shared with the receiver).

• GYC440 initialization and neutral position reading. The GYC440 is initialized when the power is turned on. In the AVCS mode, the neutral position is also read at the same time. If initialization ends normally, the operator is informed by two repetitive movements of the servo to the left and right (a little).

❗ Always check the direction of operation of the gyro.

❗ Do not strike the gyro with a hard object. Do not drop it onto a concrete surface or other hard floor.

• The sensor may become damaged during strong impacts.

❗ Do not use trims or mixing in AVCS mode.

• In the AVCS mode all corrections are made by the gyro. Therefore, if trimming and mixing, are turned on, operation will be the same as deviating from the neutral position.

❗ Do not use the GYC440 for applications other than RC cars.

• This gyro is designed for RC cars only. Do not use it for other applications.

❗ Do not place gyro near heating equipment (engine, motor, ESC, battery, servo, etc.).

• Always allow the gyro to adjust to the surrounding environmental temperature before flight. A large temperature change during use will cause drift and other operational issues.

### Connecting the GYC440

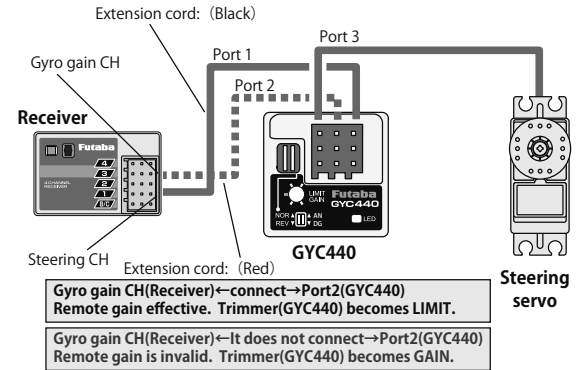

### Connecting the GYC440 (S.BUS receiver is required)

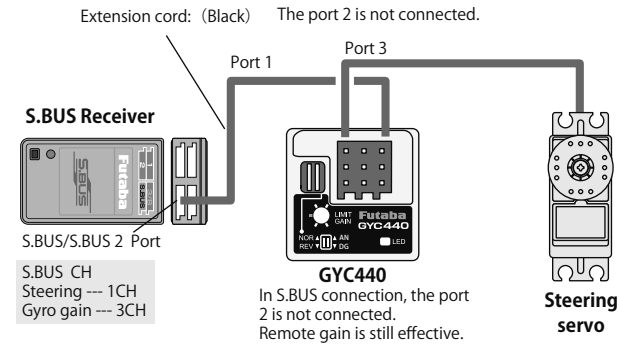

### Mounting to Chassis

Use the included double-sided sponge tape to firmly attach the gyro perpendicular to the control axis, at a position where there is as little vibration as possible. Make the wiring loose and bundle it with the included magic strap so that it will not interfere with the rod.

#### Gyro mounting position

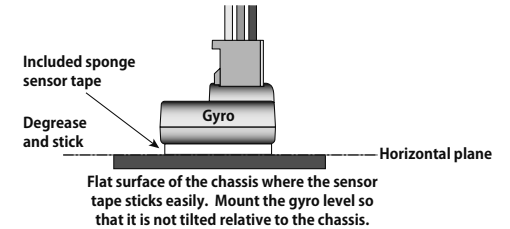
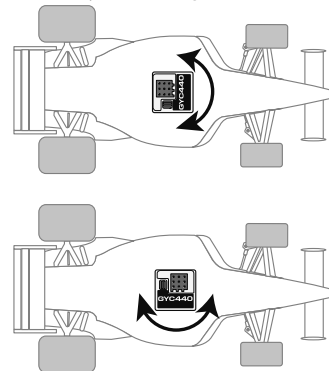

The direction of rotation fixed by the gyro can be any direction within 360° relative to the steering axis controlled by the gyro.

## Adjustments

### Servo

Link the servo in accordance with the kit instruction manual. Adjust the linkage rod so that the trim amount is as small as possible.

### Setup before a run [ Remote gain use ]

Gain adjustments are carried out with a transmitter.

Follow this procedure when the port 2 of gyro and gain CH of the receiver are connected. (or with S.BUS connection)

**1** Run the car in the gyro off and adjust the steering trim (sub trim).

**2** Select the appropriate setting for the steering servo that you are using. Servo selection switch of GYC440 should be moved to **digital (DG)** or **analog (AN)**. For best results, use a digital servo and set the GYC440 at (DG).

\*Do not use an analog servo in the digital servo mode (DG). The servo may be damaged. Use an analog servo in the analog servo mode (AN).

**3** Turn on your transmitter's power. Set the gyro sensitivity to about 50% at the NORMAL side (minus rate side) in accordance with the transmitter instruction manual. The <GAIN CH> graph of the next page is referred to.

Gyro sensitivity zero --- LED OFF  
AVCS side --- LED red  
NORMAL side --- LED green

※ Make actual sensitivity adjustment while running.

**4** Receiver ON → The GYC440 requires 3-5 seconds to initialize when the power is turned on. Do not move the car and do not move the steering wheel during this initialization or the gyro may not initialize properly. Once the initialization process has been completed the steering servo will move (a little) several times indicating that the GYC440 is now ready for use. If the neutral has shifted, LED will blink orange. In that case, it reboots.

**5** Move the steering wheel to the left and right and perform adjustment at the limit trimmer so that the servo operation angle becomes the maximum value at which the servo horn does not strike the linkage.

### <Limit Trimmer Adjustments>

Steering wheel to full



D/R (UP side)

Limit trimmer Adjustments



It adjusts to the maximum operation of linkage.

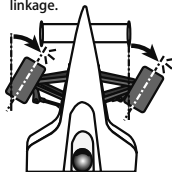

\*Limit is symmetricalness from a trim position. Limit adjustment after a steering trim adjustment.

### • Trimmer operation

\*Since this gyro is compact and light weight, the adjustment trimmer is also a small part. Always operate the trimmer with the accessory mini screwdriver and without applying unreasonable force.

**6** Using the gyro direction switch, adjust the gyro operating direction so that steering moves all the way to the right when the car is turned to the left. Be sure to set gyro operating direction correctly or the car will not run.

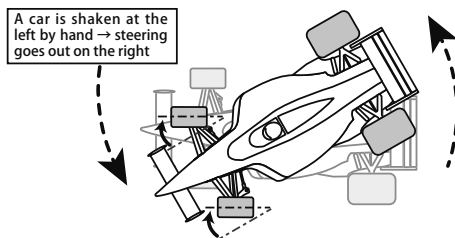

### [ When remote gain function is off ]

Adjust the gyro sensitivity with the GYC440 trimmer.

If the port 2 of gyro is not connected, remote gain is automatically set to being inhibited. (S.BUS connection is excluded)

In this case, the limit trimmer is automatically changed to gyro sensitivity setting trimmer.

(Limit adjustment cannot be performed. A limit is fixed to 55° right and left.)

**1** Select the appropriate setting for the steering servo that you are using. Servo selection switch of GYC440 is changed **digital (DG)** or **analog (AN)**. For best results, use a digital servo and set the GYC440 at (DG).

\*Do not use an analog servo in the digital servo mode (DG). The servo may be damaged. Use an analog servo in the analog servo mode (AN).

**2** Gain trimmer halfway to the left from the middle point.

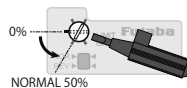

**3** Receiver ON → The GYC440 requires 3-5 seconds to initialize when the power is turned on. Do not move the car and do not move the steering wheel during this initialization or the gyro may not initialize properly. Once the initialization process has been completed the steering servo will move (a little) several times indicating that the GYC440 is now ready for use. If the neutral has shifted, LED will blink orange. In that case, it reboots.

**4** Using the gyro direction switch, adjust the gyro's operating direction so that steering moves all the way to the right when the car is turned to the left. Be sure to set the operating direction correctly or the car will not run.

### Gyro Sensitivity and AVCS Switching

When the remote gain function is used, NORMAL and AVCS mode switching is performed in accordance with the direction of operation of the transmitter's remote gain channel. At the + rate side, the AVCS mode is selected and at the - rate side, the NORMAL mode is selected. The sensitivity is changed by adjusting the end point rate.

When the remote gain function is not used, the clockwise direction from the center of the sensitivity setting trimmer is the AVCS mode and the counterclockwise direction is the NORMAL mode. At the center position the sensitivity becomes zero and when the trimmer is turned fully to the left or right, the sensitivity becomes 100%.

The sensitivity setting criteria by end point is shown in the figure below.

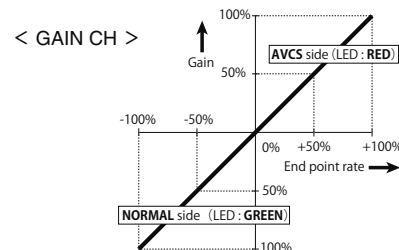

3CH (GAIN CH) is set up with reference to the manual of a transmitter. A neutral becomes GAIN 0%. It is divided into AVCS side and NORMAL side. Check using the GYC440's LED.

Gyro sensitivity zero --- LED OFF  
AVCS side --- LED red  
NORMAL side --- LED green

Trimmer movement when remote gain not used (when S.BUS is used and port 2 is not connected).

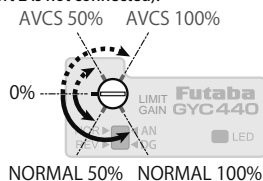

### Servo movement when the car is stopped

If steering is performed when the car is stopped, the servo will move substantially and will operate up to the limit position. In the AVCS mode, if steering is set to the neutral position, the servo will slowly return to the neutral position. This is different from ordinary operation, but is normal.

### Running Adjustment

Actually drive the vehicle and adjust the gyro sensitivity.

### [ When NORMAL mode ]

**1** Drive the vehicle and adjust the gyro sensitivity to a position. If sensitivity is too high, a steering will vibrate. Sensitivity is lowered so that it may not vibrate.

**2** The effectiveness condition of a steering is adjusted by D/R or the end point of a transmitter.

\*When the vehicle is stopped, the maximum steering angle increases as the gyro sensitivity is increased. This is because a control signal is applied from the gyro. This is different from the maximum steering angle when actually running.

### [ When AVCS mode ]

\*Steering trim must not be performed in the AVCS mode. (The gyro automatically corrects the neutral position.)

**1** Adjust steering trim with 0% gyro sensitivity or the NORMAL side.

**2** In this state turn the receiver power OFF → ON. The AVCS side neutral position is memorized and AVCS can be used. Steering trim must not be performed while the car is running.

### AVCS / NORMAL Modes

The gyro has 2 operating modes: NORMAL mode and AVCS mode. In the AVCS mode, the angle is controlled simultaneously with NORMAL mode rate control (swing speed). The AVCS mode increases straight running stability more than that of the NORMAL mode. Because the feel of operation is different, choose your favorite mode.

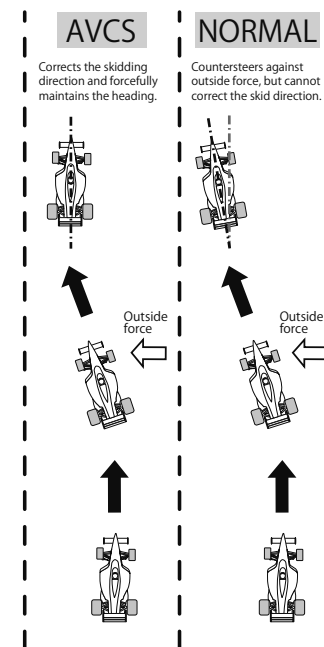

### S.BUS System

Unlike conventional radio control systems, the S.BUS system sends operating signals from the receiver to a gyro or other S.BUS compatible device by data communication. The S.BUS compatible device executes only those parts of this data for the channels set by itself. For this reason multiple servos can be connected to the same signal line.

The S.BUS system requires a dedicated S.BUS receiver and S.BUS servo (gyro, etc.).