

Before using your new gyro, please read this manual thoroughly and use the gyro properly and safely. After reading this manual, store it in a safe place.

No part of this manual may be reproduced in any form without prior permission. The contents of this manual are subject to change without prior notice. Futaba is not liable for any potential damage (accidental or otherwise) that may occur after installation.

Features of GYC441

● Dedicated RC Drift car setting

Boosts vehicle straightness and cornering ability, regardless of surface type.

● Remote gain function and mode switching function

You can adjust gain from the transmitter (3 or more CH) by using the remote gain function. Gain can also be adjusted with the trimmer on the GYC441. The mode switching function allows AVCS/NORMAL gyro mode switching.

● Integrated, compact, and lightweight

High density mounting technology makes the GYC441 compact (20.5 x 20.5 x 11 mm) and lightweight (3.7 g).

● Easy setup

The GYC441 can be used immediately with minimal setup.

● S.BUS/S.BUS2 support

Only one wire-receiver connection is needed to operate the GYC441 with S.BUS/S.BUS2.

● Only for Futaba digital servos

Functions

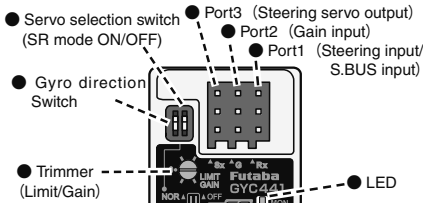

Monitor LED display

State	Color	Move	Reference
1. No servo pulse / sensor error	Red	2 flash	
2. Warm-up	Green	Fast blink	
3. Sensor initialization	Red/Green	ON	AVCS (Red) NORMAL (Green)
4. Turn	Red/Green	Fast blink	Right (Green) Left (Red)
5. Neutral offset	Orange	Slow blink	Stick operation
6. Gain OFF	—	OFF	
7. Switch operation	Green	One blink	Each time of switch operation
8. Low battery	Red	One flash	Less than 4.0V

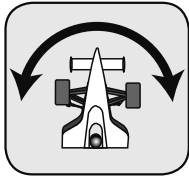

Thank you for purchasing the GYC441 RC car gyro. Compact and lightweight, the GYC441 is designed to control steering in your RC car. If the transmitter has 3 or more channels (capable of 3CH adjustment), gyro sensitivity can be adjusted from the transmitter.

Features include simple set-up and S.BUS/S.BUS2 connectivity.

GYC441 Ratings:

- (Integrated sensor type rate gyro)
- Gyro sensor: MEMS vibrating structure gyro
- Operating voltage: DC 4.2V to 8.4V
- Current drain: 30mA (excluding a servo)
- Operating temperature range: -10 °C to +45 °C
- Dimensions: 20.5 x 20.5 x 11.0 mm (0.8 x 0.8 x 0.43 in) (except connector)
- Weight: 3.7 g (0.13 oz)
- Functions: Sensitivity trimmer. LED monitor. Servo selection (SR mode ON/OFF). S.BUS/S.BUS2 connection.

Set Contents

The following items are supplied with the GYC441:

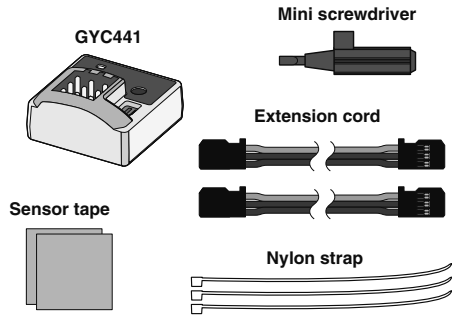

⚠WARNING

Failure to follow these safety precautions may result in severe injury to yourself and others.

❶ Check that there is sufficient battery capacity.

❷ Do not operate the model and transmitter steering wheel for about 3-5 seconds after turning on the GYC441 (When shared with the receiver).

• The GYC441 is activated when the power is turned on. The neutral position is also read at the same time. If initialization is successful, you will see the servo move left and right slightly.

❸ Always check the direction of operation of the gyro.

❹ Do not strike the gyro with a hard object. Do not drop it onto a concrete surface or other hard floor.

• The sensor may become damaged during strong impacts.

❺ Do not use trims or mixing.

• All corrections are made by the gyro. Therefore, if trimming and mixing are turned on, operation will be the same as driving from the neutral position.

❻ Do not use the GYC441 for applications other than RC cars.

• This gyro is designed for RC cars only. Do not use it for other applications.

❼ Analog servos cannot be used.

• The use of analog servos may cause servo damage.

❽ Do not place gyro near heating equipment (engine, motor, ESC, battery, servo, etc.).

• Always allow the gyro to adjust to the outside temperature before driving. A large temperature change during use will cause drift and other operational issues.

Connecting the GYC441

Gyro gain CH(Receiver) ← connect → Port2(GYC441)
Remote gain effective. Trimmer(GYC441) becomes LIMIT.

Gyro gain CH(Receiver) ← It does not connect → Port2(GYC441)
Remote gain is invalid. Trimmer(GYC441) becomes GAIN.

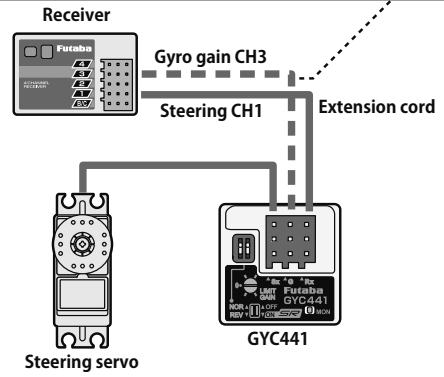

S.BUS Connecting the GYC441

* When using SR mode, SBUS connection is not possible. When using SR mode, connect as shown on the left.

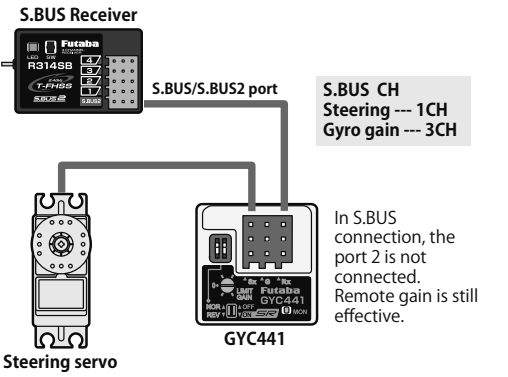

In S.BUS connection, the port 2 is not connected. Remote gain is still effective.

Mounting to Chassis

Use the included double-sided sponge tape to firmly attach the gyro perpendicular to the control axis, at a position where there is as little vibration as possible. Make the

wiring loose and bundle it with the included nylon strap so that it will not interfere with the rod.

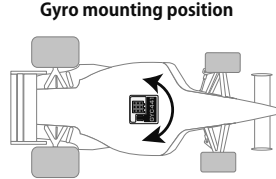

The direction of rotation fixed by the gyro can be any direction within 360° relative to the steering axis controlled by the gyro.

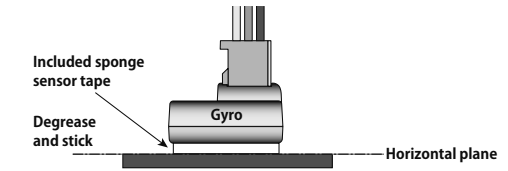
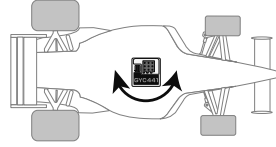

Flat surface of the chassis where the sensor tape sticks easily. Mount the gyro level so that it is not tilted relative to the chassis.

Steering servo

Link the servo according to the kit instruction manual. Adjust the linkage rod so that the trim amount is as small as possible.

When using S.BUS servo, initialize a parameter. Make the servo operating range as wide as possible.

Equalize EPA (ATV) left and right.

SR mode

It is possible when using the T7PX to change the servo to "SR Mode" and improve the servo response. If the servo can't be changed to SR mode, do not set the TX to SR mode.

Adjustments.

Setup before a run [Remote gain use]

Gain adjustments are carried out with a transmitter.

Follow this procedure when the gyro's port 2 and the receiver's gain CH are connected (or connected via S.BUS).

1 Run the car in the gyro off mode (**gyro gain 0%**) and adjust the **steering trim** (sub trim).

2 Select the appropriate setting for the steering servo that you are using. Servo selection switch of GYC441 should be moved to **SR mode ON** or **OFF**.

*Do not use a normal digital servo in the SR servo mode (ON). The servo may be damaged. Use a **normal digital servo** in the **SR servo mode (OFF)**.

3 Turn on your transmitter's power. Set the gyro sensitivity to about 70% at the NORMAL or AVCS side in according to the transmitter's instruction manual. Refer to the <GAIN CH> <AVCS / NORMAL Modes> graph on the next page.

Gyro sensitivity zero --- LED OFF
AVCS side --- LED red
NORMAL side --- LED green

*Make the gain tuning adjustment after running the car and noting the behavior.

4 Receiver ON → The GYC441 requires 3-5 seconds to initialize when the power is turned on. Do not move the car and do not move the steering wheel during this initialization or the gyro may not initialize properly. Once the initialization process has been completed, the steering servo will move slightly several times, indicating that the GYC441 is now ready for use. If the neutral has shifted, the LED will blink orange. In that case, it reboots.

5 Move the steering wheel left and right and adjust the limit trimmer to maximize servo operation without binding the control linkage or mechanical limits.

<Limit Trimmer Adjustments>

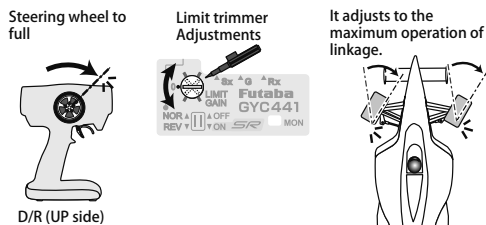

*Limit is symmetrical from the neutral position. Only proceed with the limit adjustment after completing the trim adjustment.

● Trimmer operation

*Since this gyro is very small, the adjustment trimmer is a small part. Always operate the trimmer with the included mini screwdriver without applying excessive force.

6 Using the gyro direction switch, adjust the gyro direction so that steering moves all the way to the right when the car is turned to the left. Correctly set gyro operating direction or the car will not run.

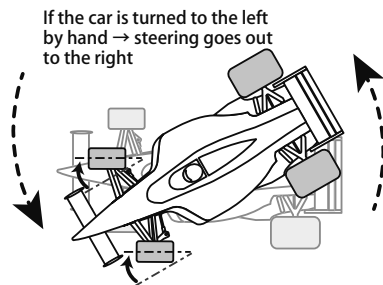

[When remote gain function is off]

Adjust the gyro sensitivity with the GYC441 trimmer.

If port 2 of gyro is not connected, remote gain is automatically prohibited. (S.BUS connection is excluded)

In this case, the limit trimmer is automatically changed to the gyro sensitivity setting trimmer.

(Limit adjustment cannot be performed. A limit is fixed to 50 right and left.)

1 Select the appropriate setting for the steering servo that you are using. The GYC441's servo selection switch of GYC441 should be moved to **SR mode ON** or **OFF**.

*Do not use a normal digital servo in the SR servo mode (ON). The servo may be damaged. Use a **normal digital servo** in the **SR servo mode (OFF)**.

2 Gain trimmer halfway to the left : NORMAL(green) or right : AVCS (red) from the 70% point.

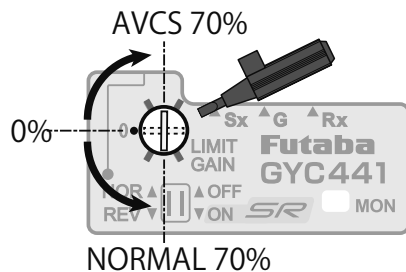

3 Receiver ON → The GYC441 requires 3-5 seconds to initialize when the power is turned on. Do not move the car and do not move the steering wheel during this initialization or the gyro may not initialize properly. Once the initialization process has been completed, the steering servo will

to the right when the car is turned to the left. Correctly set the operating direction or the car will not run.

Gyro Sensitivity and mode Switching

When the remote gain function is used, **NORMAL** and **AVCS** mode switching is performed in accordance with the direction of operation of the transmitter's remote gain channel. At the **+ rate side**, the **AVCS** mode is selected and at the **- rate side**, the **NORMAL** mode is selected. The sensitivity is changed by adjusting the end point rate.

When the remote gain function is not used, the clockwise direction from the center of the sensitivity setting trimmer is **AVCS** mode and the counterclockwise direction is **NORMAL** mode. At the center position, the sensitivity becomes zero and when the trimmer is turned fully to the left or right, the sensitivity becomes 100%.

The sensitivity setting criteria by end point is shown in the figure below.

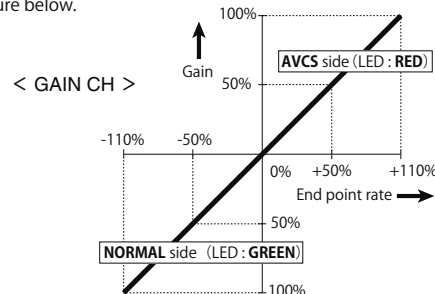

3CH (GAIN CH) is set up with reference to the transmitter manual. Neutral position becomes GAIN 0%. It is divided into AVCS side and NORMAL side. Refer to the GYC441's LED.

Gyro sensitivity zero --- LED OFF
AVCS side --- LED red
NORMAL side --- LED green

When Port 2 is not used for gain and SBUS/SBUS2 is not used, the trimmer works as the gain adjustment shown below.

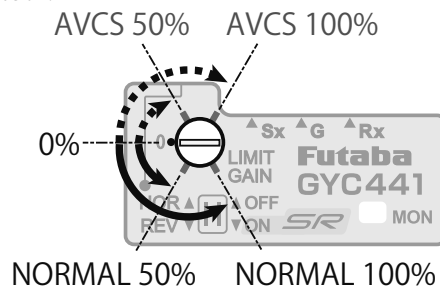

Tuning Adjustment

Drive the vehicle and adjust the gyro sensitivity.

1 Always **re-trim** with the **gyro gain at 0**.

2 In this state, turn the **receiver power OFF → ON**. The neutral position is memorized. Steering trim must not be performed while the car is running.

AVCS / NORMAL Modes

The gyro has 2 operating modes: **NORMAL** mode and **AVCS** mode. In **AVCS** mode, the angle is controlled simultaneously with **NORMAL** mode's rate control (swing speed). The **AVCS** mode increases straight stability more than **NORMAL** mode. Choose your mode to match your preferences.

AVCS

Corrects the skidding direction and forcefully maintains the heading.

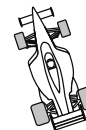
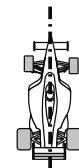

NORMAL

Countersteers against outside force, but cannot correct the skid direction.

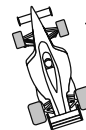

S.BUS System

Unlike conventional radio control systems, the S.BUS system sends operating signals from the receiver to a gyro or other S.BUS compatible devices by data communication. The S.BUS compatible device executes only executes data for the channels it sets. For this reason, multiple servos can be connected to the same signal line.

The S.BUS system requires a dedicated S.BUS receiver and S.BUS servo (gyro, etc.).