

Futaba® R2001SB

**S-FHSS 2.4GHz System
S.BUS Port and 1 Channel (CH3) for Conventional System
Receiver**



Thank you for purchasing a Futaba **R2001SB S-FHSS 2.4GHz** compatible receiver.

The **R2001SB** has an **S.BUS** system output port and a conventional system channel output. It can also be used with conventional system servos, etc. in addition to **S.BUS** system compatible servos and gyros.

Applicable systems: Futaba S-FHSS 2.4GHz system and TM-FH RF Module

Usage precaution

- Futaba S-FHSS system does not work with current Futaba FASST/FASSTest/T-FHSS system. Futaba FASST/FASSTest/T-FHSS system and S-FHSS system are not compatible to each other.

⚠ WARNING

❗ Wrap the receiver with something soft, such as foam rubber, to avoid vibration. Moreover, the receiver must not get wet.

⊘ **Do not short-circuit the connectors.**

⊘ **Do not expose the receiver to high temperatures.**

- The shrink cover could become distorted.

⊘ **Do not break the tube.**

- Could cause a short circuit.

❗ When inserting and removing a connector, hold the receiver tightly.

- Be careful so that a tube doesn't come off.

Antenna installation precaution

⊘ **Do not cut or bundle the receiver antenna wire.**

⊘ **Do not bend the coaxial cable. It causes damage.**

❗ **The antenna should not be pulled.**

❗ **Keep the antenna as far away from the motor, ESC and other noise sources as you possibly can.**

⊘ **Do not touch the antenna to metal, carbon, or other conductive material.**

❗ **Be sure that the two antennas are placed at 90 degrees to each other.**

- The R2001SB has two antennas. In order to maximize signal reception and promote safe modeling Futaba has adopted a diversity antenna system. This allows the receiver to obtain RF signals on both antennas and fly problem-free.

Antenna installation for carbon fuse

⚠ WARNING

❗ **The antenna portion of 30mm tip must be fully exposed.**

- Please make sure that the exposed portion won't slide back in the fuse due to wind pressure or other force during the flight session.

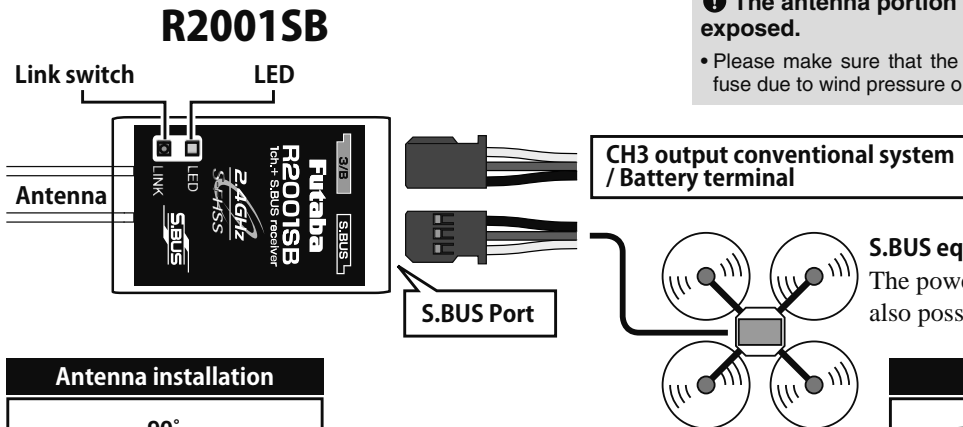

S.BUS equipment

The power supply from S.BUS port is also possible.

Antenna installation

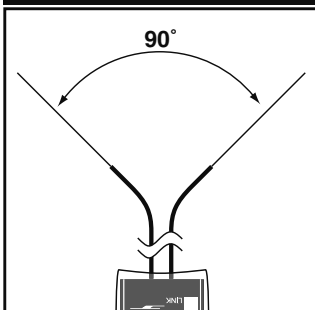

Please refer the table below for LED status vs receiver's condition.

LED Indication

Green	Red	Status
Off	Solid	No signal reception
Solid	Off	Receiving signals
Blink	Off	Receiving signals but ID is unmatched
Alternate blink		Unrecoverable error (Memory, etc.)

Direction of the connectors

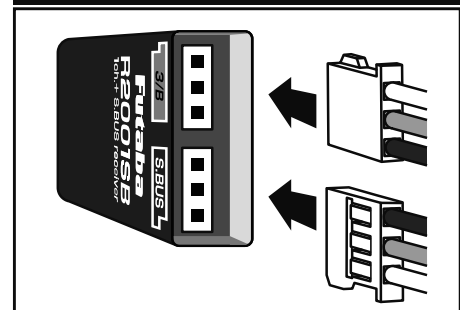

R2001SB Specifications

S-FHSS 2.4GHz system/S.BUS port and 1 channel for conventional system receiver

- Dual antenna diversity
- Size: 0.83 x 1.65 x 0.21 in. (21.1 x 41.8 x 5.3 mm)
- Weight: 0.15 oz. (4.2g)

- Power requirement: 4.8V to 7.4V
- Battery F/S Voltage: 3.8V

* Be sure that when using ESC's regulated output the current capacity of the ESC meets your usage condition.

* **The Battery F/S voltage is set for 4-cell NiCd/NiMH battery. Battery F/S function doesn't work properly when a different type of battery is used.**

* **S.BUS port:** R2001SB can be used with up to 8 channels. However, it differs according to the transmitter. An unused channel is a neutral signal. The F/S setting channel at F/S is F/S position. Another, it is Hold signal.

* The fail safe function can be set for each channel. However, it differs according to the transmitter. When you use TM-FH RF Module, the fail safe function can be set for channel 3 only.

Link to the transmitter

- 1 Bring the transmitter and the receiver close to each other, within 20 inches (half meter).
- 2 Turn on the transmitter.
- 3 Turn on the receiver.
- 4 Press and hold the **Link switch** more than two (2) seconds. When the link is complete, the LED in the receiver changes to **solid green**. When the ID cannot be read due to the surrounding environment, try reading it with the transmitter and receiver antennas touched.

- When you use TM-FH RF Module, the fail safe function can be set for channel 3 only.
- If there are many S-FHSS systems turned on in close proximity, your receiver might not link to your transmitter. In this case, even if the receiver's LED stays solid green, unfortunately the receiver might have established a link to one of other transmitters. This is very dangerous if you do not notice this situation. In order to avoid the problem, we strongly recommend you to double check whether your receiver is really under control by your transmitter by giving the stick input and then checking the servo response.

⚠ WARNING

⊘ **Do not perform the linking procedure with the motor's main wire connected or the engine operating as it may result in serious injury.**

ⓘ **When the linking is done, please cycle receiver power and check if the receiver to be linked is really under the control of the transmitter to be linked.**

What is S.BUS?

Different from conventional radio control systems, the **S.BUS** system uses data communication to transmit control signals from a receiver to a servo, gyro, or other **S.BUS** compatible devices. This data includes commands such as “move the channel 3 servo to 15 degrees, move the channel 5 servo to 30 degrees” to multiple devices. The **S.BUS** devices execute only those commands for their own set channel. For this reason, it can be used by connecting multiple servos to the same signal line.

⚠ WARNING

ⓘ **Turn on the power on transmitter → receiver in order. In addition, always check the operation of all the functions before flight.**

⚠ WARNING

⊘ **Do not insert or remove the S.BUS connector while the receiver power is ON.**

Since the S.BUS servo switches the operation mode automatically according to the type of signal (S.BUS signal/PWM signal) from the receiver, if the connector is inserted or removed while the power is ON, an S.BUS connected servo will be erroneously recognized and may stop.

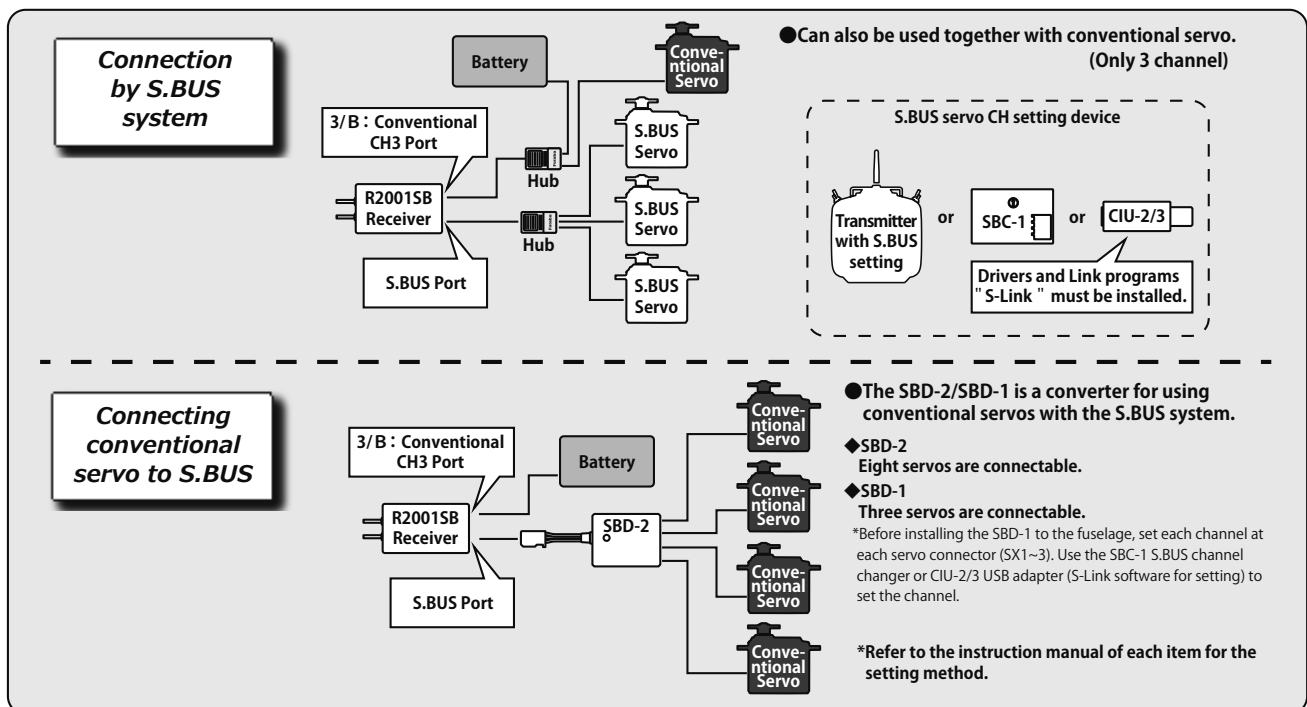

FUTABA CORPORATION

oak kandakajicho 8F 3-4 Kandakajicho, Chiyoda-ku, Tokyo 101-0045, Japan TEL: +81-3-4316-4820, FAX: +81-3-4316-4823

©FUTABA CORPORATION 2018, 5 (2)