

# Futaba

High Voltage System *P.G.CAR SERVO* 



## S9470SV

### S9470SV

### *P.G.CAR SERVO*

|        |            | at 6.0V | at 7.4V |
|--------|------------|---------|---------|
| SPEED  | (sec/60°)  | 0.11    | 0.09    |
| TORQUE | (kgf · cm) | 11.4    | 13.8    |
|        | (ozf · in) | 158.4   | 191.7   |

SIZE 40.0×20.0×36.6 mm  
(1.57×0.79×1.44 in)

WEIGHT 54.0g (1.90 oz)

RATED VOLTAGE DC6.0V~7.4V

OPERATING VOLTAGE DC4.0V~8.4V

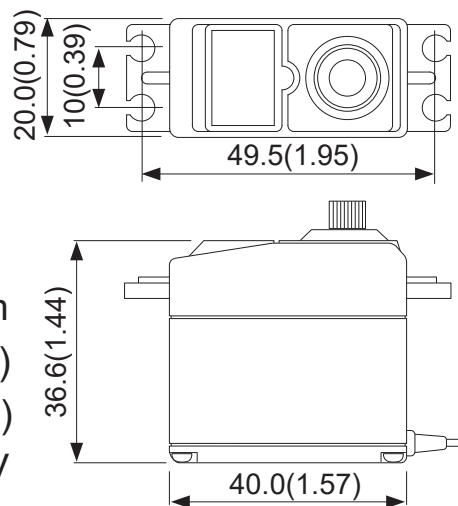

**No dry battery use**

Unit : mm(in)

## ⚠ WARNING

❗ **Turn on the power in transmitter → receiver order. In addition, always check the operation of all the servos before use.**

⊘ **Do not insert or remove the servo connector while the receiver power is ON.**

- Since the S.BUS2 servo switches the operation mode automatically according to the type of signal (S.BUS signal/PWM signal) from the receiver, if the connector is inserted or removed while the power is ON, an S.BUS connected servo will be erroneously recognized and may stop.

⊘ **Do not leave the servo in the locked state.**

- Leaving the servo in the locked state (state in which enough force is applied that the servo cannot move) may cause smoke, fire, and damage.

⊘ **Never connect the battery in reverse.**

- Reverse connection may cause smoke, fire, and damage.

⊘ **Do not expose the servo to dust and water.**

- The servo does not have a waterproof construction. If it gets wet, the servo may not operate or the power supply may short circuit.

❗ **When installing the servo, check PUSHROD LINKAGE to make sure there is no binding in order to prevent excessive power consumption and decrease the life of the motor and battery.**

## ⚠ CAUTION

⊘ **Do not touch the servo case immediately after servo operation.**

- You may be burned because the motor and circuits inside the servo become hot.

⊘ **Do not turn the servo horn with unreasonable force.**

- The servo may be damaged.

⊘ **Do not disassemble or modify the servo.**

- The servo has a precision construction. Futaba Corp. will not be responsible for any disassembly or modification other than those specified by us.

⊘ **Do not drop the servo or expose it to strong shocks or vibrations.**

- It will damage with a shock.

❗ **Use the servo as an actuator in hobby applications.**

- Futaba will not be responsible if the servo is used in applications other than the above.

**Futaba will not be responsible for damage, etc. caused by the use of parts other than Genuine Futaba parts.**

## •Power supply

Use the battery as specification. Use a battery or a voltage regulator with an ample margin as the power supply. The specified performance cannot be displayed with a dry cell battery.

Even if using a receiver with the BATTERY FAIL SAFE function, it may not operate correctly. Therefore, decide the safe number of uses by paying careful attention to the remaining battery capacity.

## •System use

For full performance, 2.4GHz system is recommended.

Use this servo by car receiver. This servo cannot be used by air receiver.

## •Programming function(P.G.)

This servo has **Futaba S.BUS2** system. This servo can be connected to a PC by using the CIU-2 USB Adapter sold separately and its various operating characteristics can be changed as a programmable servo by means of dedicated software "**S-Link**". **S-Link** is downloadable from a Futaba WEB site. Depending on a setup, a servo carries out vibration. If a servo continues carrying out vibration, it will break, please restore a setup.

### [Servo Mounting Precautions]

- Use attached dampers and eyelets correctly.

