

# Voltage sensor SBS-01V

## Instruction Manual

Thank you for purchasing Futaba's SBS-01V Voltage Sensor. This sensor, used in conjunction with a telemetry enabled transmitter/receiver, is used to indicate the voltage of the item to which it is attached. Although the telemetry receiver of Futaba's has a function which measures voltage, if SBS-01V is used, it can measure more battery voltage. To maximize your enjoyment, and to ensure proper sensing, please read through this manual thoroughly. We also encourage you to retain the manual for future reference should the need arise.

● The SBS-01V is designed for use with Futaba telemetry systems.

### Features

Measures receiver battery voltage and the voltage of a second battery or power supply.

External Line Range : 0-100V's

Normal Line Range : 3.5-8.4V's

Weight : 0.2oz (6.0g)

Length : 34.25in (870mm)

### WARNING

Failure to follow these safety precautions may result in severe injury to yourself and others.

❗ To utilize the SBS-01V altitude sensor, connect it to the S.BUS2 port of the Futaba telemetry enabled receivers.

■ The SBS-01V will not function properly if connected to an S.BUS port or other channel ports.

❗ Ensure that the unit is connected properly to the receiver. Failure to do so could result in damage to the sensor.

❗ Ensure that the unit is mounted in an area that will eliminate exposure to fuel, water and vibration.

■ As with any electronic components, proper precautions are urged to prolong the life and increase the performance of the SBS-01V.

❗ To ensure that the SBS-01V is functioning as desired, please test accordingly.

■ Do not fly until inspection is complete.

⊘ Do not use the SBS-01V with anything other than an R/C model.

❗ In order to prevent any short circuits, please observe the polarity of all connections.

■ Ensure that the unit is connected properly; failure to do so could result in damage to the cable, receiver, etc.

❗ Always mount the cable in accordance with the instructions included in this manual.

❗ Allow a slight amount of slack in the cable.

■ If necessary, fasten this cable at a suitable location to prevent any damage from vibration during flight.

❗ Turn on the receiver prior to connecting the Extra Voltage Input.

❗ To prevent any short circuits, please ensure that the cable is routed away from any conductive materials.

⊘ Don't apply voltage higher than 100V to Extra voltage line.

■ There is fear of explosion, ignition, and breakage.

❗ It is cautious of the burn and fire in wiring work enough.

⊘ The work of wiring must not connect a battery.

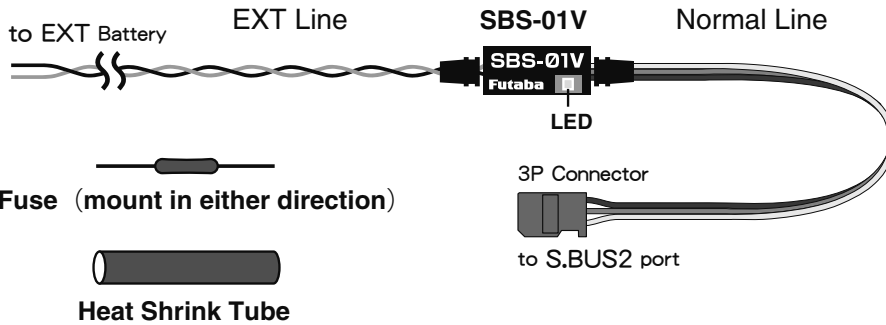

### LED Indication

Green	Normal operation
Red	No signal reception
Green/Red	When setting up the slot
Green/Red Alternate blink	Unrecoverable error

### Slot Number Setup

SBS-01V uses two continuous slots. Please note that the proper default start slot for this accessory is number 6. When setup-changing or adding, it is the following numbers that are made to a start slot.

1,2,3,4,5,6,8,9,10,11,12,13,14,16,17,18,19,20,21,22,24,25,26,27,28,29,30  
Information on how to change the slot assignment is included in the transmitter's manual.

### Battery connection

What is measured is total voltage when the battery which you want to measure has two or more cells. One cell of a battery with many cells cannot be measured. Don't carry out connection wiring at one cell. If it connects with one cell, there is fear of ignition.

### The example of wiring

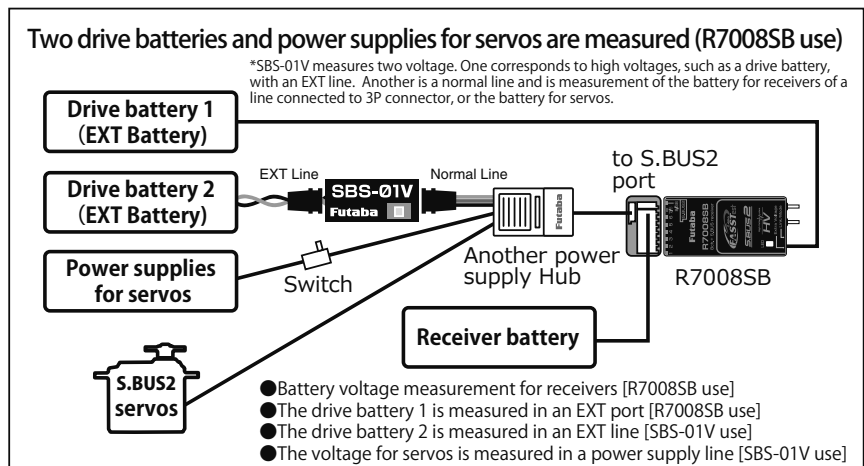
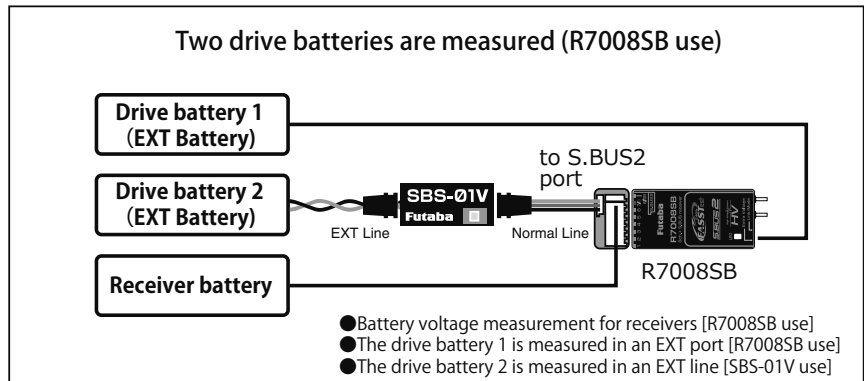

① Measure the cable and then cut it to the desired length.

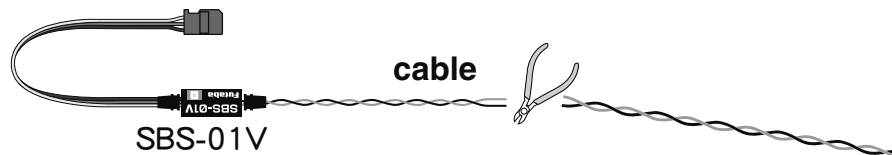

② Cut approximately 30mm of the negative (-, black) line from the cable. Solder the fuse inline on the negative wire and then reattach the section of wire that was previously removed. The fuse should be attached as close to the external power supply as possible.

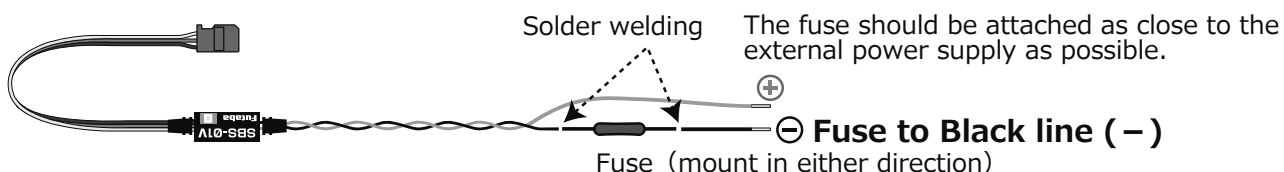

③ Place a piece of heat shrink tubing over the fuse, ensuring that it covers the soldered areas. Shrink the tubing snug to the fuse and the wire using a heat gun.

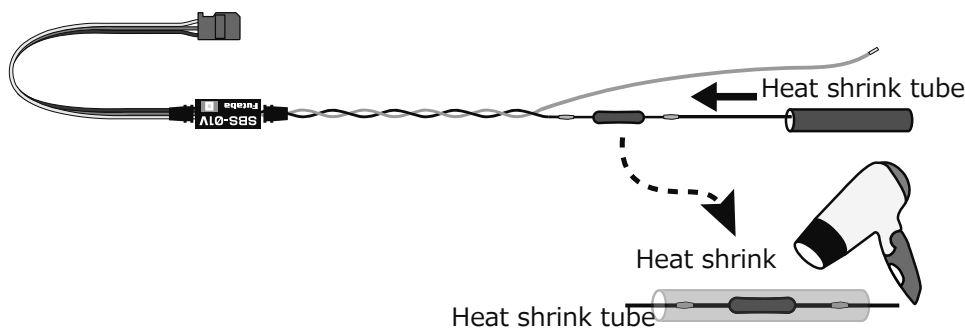

④ The cable should be connected as shown in the diagram below. The cable gets connected to the wires that come off the ESC and connect to the battery.

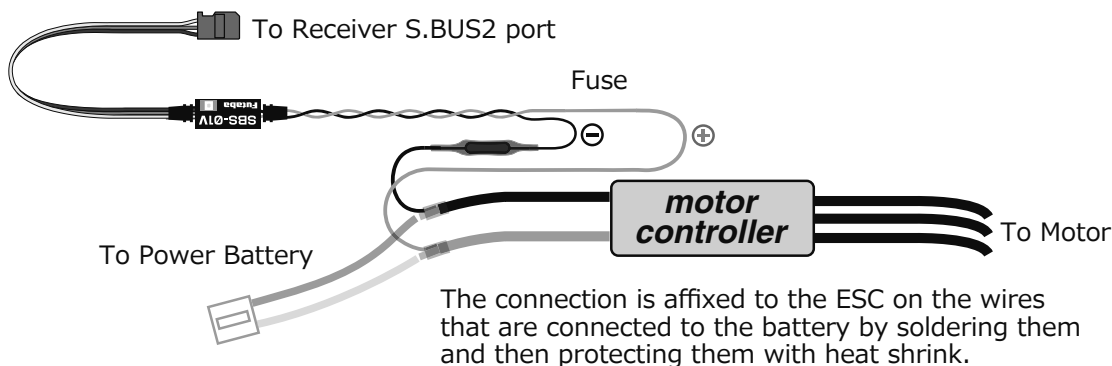

⑤ The manual for the Telemetry system should be referred to after the setup is complete; checking to make sure it functions as desired and that it provides the correct voltage on the display.

