

Multi-Prop Decoder
MPDX-1



INSTRUCTION MANUAL

Applicable systems;

32MZ/18MZ(WC) system

**14MZ/FX-40/12Z/12FG system
(except 2.4GHz system)**

Before using your new MPDX-1, please read this manual thoroughly and use the system properly and safely. After reading this manual, store it in a safe place.

- No part of this manual may be reproduced in any form without prior permission.
- The contents of this manual are subject to change without prior notice.
- This manual has been carefully written. Please write to Futaba if you feel that any corrections or clarifications should be made.

Thank you for purchasing a MPDX-1 Multi-Prop Decoder.

The MPDX-1 connects to the receiver output of a 32MZ/18MZ/14MZ/FX-40/12Z/12FG System and expands the signal of one channel to 8 channels.

Features

- Servo operation of 8 channels is possible with 1 channel.
- Linear operation is possible.
- The servo operation speed of each channel can be set.
- Fail-safe setting of each channel is possible.
- Operation control setting, direction of operation change, and travel adjustment are possible for each multi-prop expanded channel. (Transmitter side setting).
- 32MZ multiprop function is a function that divides one channel into eight channels and extends the number of channels. Up to 2 MPDX-1 can be used, and up to 32 channels can be expanded as follows.
 - Linear channel 14 channels (2 channels are used by multi-prop function)
 - ON/OFF channel 2 channels
 - Multiprop channels 16 channels

Multiprop channels have the following differences from normal linear channels.

- The resolution of the multiprop channel is lower than that of the linear channel.
- Operating multiple multiprop channels simultaneously may reduce the operation response of the multiprop channel.
- Multiprop channels can not use the mixing function.

Connections and Name of Each Part of the MPDX-1

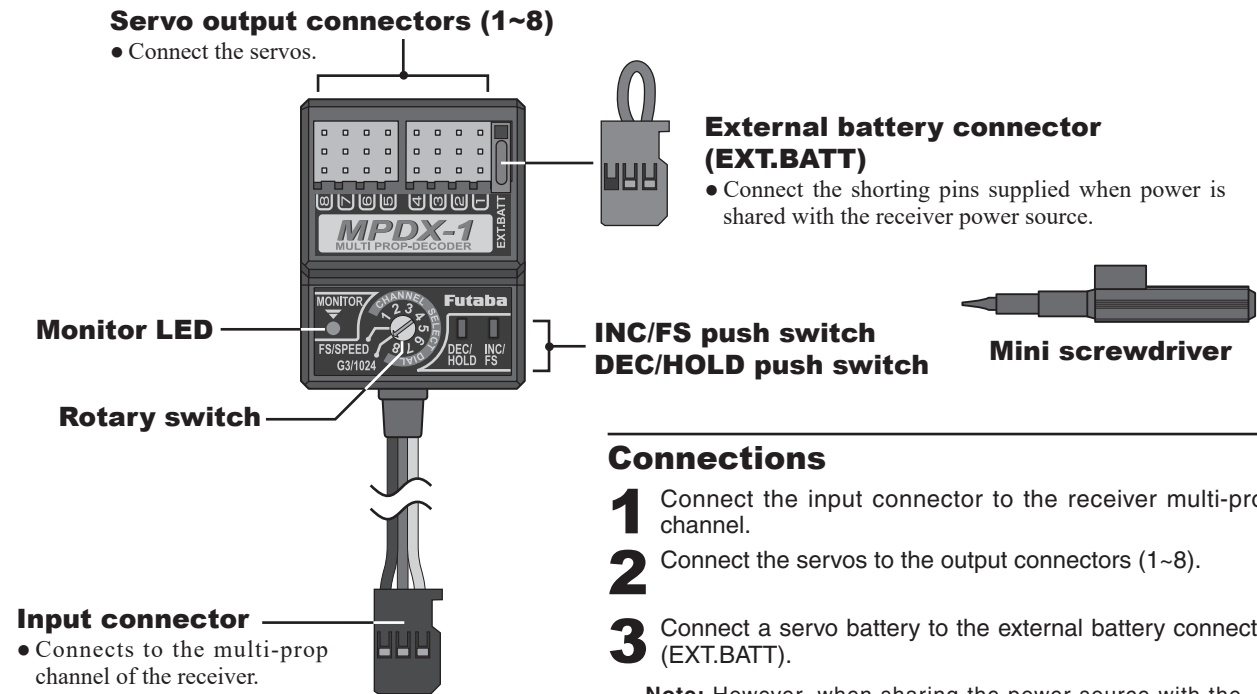

•MPDX-1 can not be used on S.BUS/S.BUS2. Use with conventional channels.

Connections

- 1** Connect the input connector to the receiver multi-prop channel.
- 2** Connect the servos to the output connectors (1~8).
- 3** Connect a servo battery to the external battery connector (EXT.BATT).

Note: However, when sharing the power source with the receiver, connect the shorting pins.

CAUTION

When the number of servos is large, we recommend the use of a separate power supply.

32MZ Transmitter Setup

Multi-prop function assignment

Open the function setup window of the linkage menu and set the function of the channel to which the MPDX-1 is connected to "Multi-prop 1" or "Multi-prop 2".

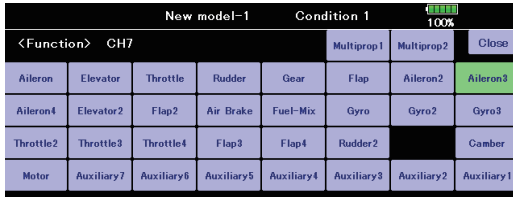

(Windows with "Multi-prop 1" and "Multi-prop 2" set)

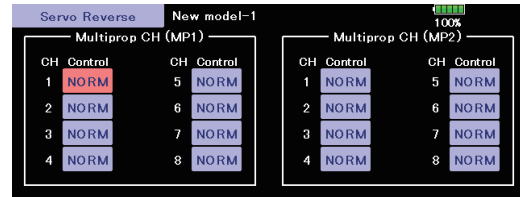

Travel adjustment:

1 Open the end point (ATV) window of the linkage menu and push the "MP CH" button of the channel with multi-prop set.

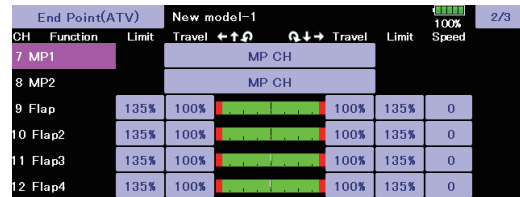

2 The end point (ATV) setup window of the multi-prop channel opens. Press the display button (left or right or up and down can be adjusted individually) of the channel whose travel you want to adjust, and adjust the rate by using the adjustment buttons at the bottom.

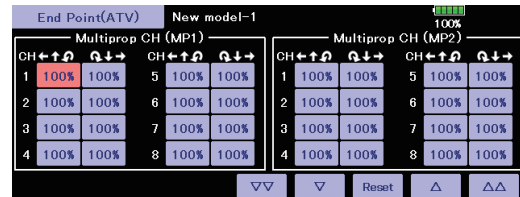

Operation control setting:

1 Open the operation setup window by pushing the "MP CH" button of the channel with multi-prop set.

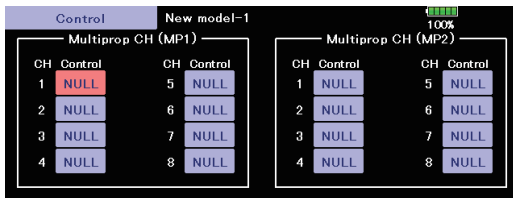

2 Open the control selection window by pushing the button of the multi-prop channel to be set.

3 Select the control you want to operate.

Reverse setting:

1 Open the reverse setup window of the linkage menu, and push the SET button of the channel with multi-prop set.

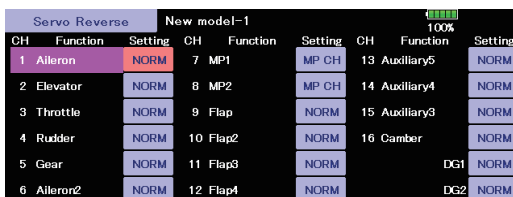

2 The reverse setup window of the multi-prop channel appears. Switch between "Normal" and "Reverse" by pushing the SET button of the multi-prop channel you want to reverse.

•The system that can use MPDX-1 is FASSTest18CH/ FASST-MULTI.

It can not be used on other systems.

MPDX-1 setting

Rotary switch

FS/SPEED: F/S setting/servo operation speed setting mode switching

1~8: Setting channel switching

G3/1024:

● 2.4GHz/PCMG3 ● PCM1024 ● PPM
3 modes switching

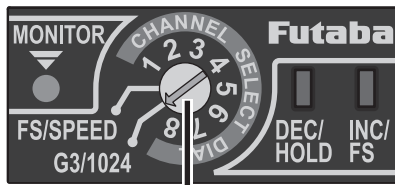

INC/FS push switch

- SPEED setting: Delay is increased by pushing
- F/S setting: F/S mode is set by pushing

DEC/HOLD push switch

- SPEED setting: Delay is decreased by pushing
- F/S setting: HOLD mode is set by pushing

Operation monitor indicator LED (MONITOR)

Rotary switch position	Monitor LED state					
	Off	On	Slow blink	Intermittent blink	Intermittent double blink	Single blink
FS/SPEED	FS/HOLD mode		SPEED setting mode			
1-8 (In FS/HOLD setting mode)	HOLD	F/S				At switching of rotary switch
1-8 (In SPEED setting mode)	SPEED setting minimum	SPEED setting maximum		SPEED setting 4 or less	SPEED setting 5 or greater	
G3/1024	2.4GHz/PCMG3 mode	PPM mode	PCM1024 mode			

Fast blink: At FS operation, receive data error, or backup error

⚠ CAUTION

Always use the miniature screwdriver supplied to operate the MPDX-1 rotary switch and push switches.

*Do not apply excessive force while operating.

Operation mode setting

Set the operation mode to match the mode of the receiver used.

- 1 Set the rotary switch to the "G3/1024" position.
- 2 Switch the mode to match the type of receiver. (2.4GHz/PCMG3, PCM1024, PPM mode).

*Each time the "INC/FS" (or "DEC/HOLD") push switch is pushed for 1 second, the 2.4GHz/PCMG3, PCM1024, and PPM mode is alternately selected. When the LED is off, the MPDX-1 is in the 2.4GHz/PCMG3 mode, when the LED blinks slowly, the MPDX-1 is in the PCM1024 mode, and when the LED lights steadily, the MPDX-1 is in the PPM mode.

F/S mode/HOLD mode setting

The operation mode of each servo when the receiver cannot receive signals normally can be set.

F/S mode: Servo moves to a preset position.

HOLD mode: Servo remains in its present position.

- 1 Set the rotary switch to the "FS/SPEED" position.
- 2 Push the "INC/FS" (or "DEC/HOLD") push switch to turn off the LED.

*Each time the push switch is pressed, the LED toggles between off and slow blink.

- 3 Set the rotary switch to the channel # you want to set to the F/S mode or HOLD mode.

When you want to set the channel to the F/S mode, move the servo to the F/S operation position at the transmitter side and push the "INC/FS" switch.

*When setting is complete, the LED lights.

When you want to set the channel to the HOLD mode, press the "DEC/HOLD" switch.

*When setting is complete, the LED goes off.

Servo speed setting

The delay of each servo can be set. The delay can be set within the 0 (no delay) to 10 (maximum delay) range.

- 1 Set the rotary switch to the "FS/SPEED" position.
- 2 Push the "INC/FS" (or "DEC/HOLD") push switch to slowly blink the LED.

*Each time the switch is pressed, the LED toggles between off and slow blink.

- 3 Set the rotary switch to the channel # whose delay you want to set.

When you want to increase the delay, push the "INC/FS" push switch.

When you want to decrease the delay, push the "DEC/HOLD" push switch.

*When the delay is zero, the LED goes off, when the delay is 4 or less, the LED blinks intermittently, and when the delay is 5 or greater, the LED blinks intermittently twice. The delay step is 10 steps. When maximum delay is set, the LED lights steadily.

[MPDX-1 Ratings]

- Operation power requirement: 4.8 V - 7.4 V
- Current drain: 7.5 mA
- Number of multi-prop output channels: 8
- Applicable modulation modes: 2.4GHz/PCMG3, PCM1024, PPM
- Multiplexing scheme: Pulse width division (2.4GHz/PCMG3, PCM1024), time division (PPM)
- Delay function: Settable for each channel
- Fail-safe function: F/S function/HOLD function can be selected for each channel.
- Weight: 14.2 g
- Dimensions: 29.6x39.3x15.8 mm

Repair Service

Before requesting repair, read this instruction manual again and recheck your system. Should the problem continue, request repair service as follows:



Describe the problem in as much detail as possible and send it with a detailed packing list together with the parts that require service.



- Symptom (Including when the problem occurred)
- System (Transmitter, Receiver, Servo's and model numbers)
- Model (Model name)
- Model Numbers and Quantity
- Your Name, Address, and Telephone Number.

If you have any questions regarding this product, please consult your local hobby dealer or contact the Futaba Service Center.

Special Markings;

Pay special attention to the safety at the parts of this manual that are indicated by the following marks.

[Symbol]  ; Prohibited  ; Mandatory

Mark	Meaning
 DANGER	Procedures which may lead to a dangerous condition and cause death or serious injury to the user if not carried out properly.
 WARNING	Procedures which may lead to a dangerous condition or cause death or serious injury to the user if not carried out properly, or procedures where the probability of superficial injury or physical damage is high.
 CAUTION	Procedures where the possibility of serious injury to the user is small, but there is a danger of injury, or physical damage, if not carried out properly.

FUTABA CORPORATION

oak kandakajicho 8F 3-4 Kandakajicho, Chiyoda-ku, Tokyo 101-0045, Japan

TEL: +81-3-4316-4820, FAX: +81-3-4316-4823

©FUTABA CORPORATION 2019, 6 (3)