

Futaba®

6EXHP



INSTRUCTION MANUAL
for Futaba 6EXHP 6-channel,
PCM/PPM(FM) selectable
Radio control system for helicopter

Futaba Corporation

Technical updates available at: <http://www.futaba-rc.com>

Entire Contents © Copyright 2005



1M23N12008
FUTZ8564 V1.0

TABLE OF CONTENTS

<p>Introduction2</p> <p>Service2</p> <p>Contents and specifications.....3</p> <p>Introduction to the 6EXAP system.....4</p> <p>Transmitter controls and descriptions4</p> <p>Radio installation5</p> <p>Receiver and servo connections7</p> <p>Charging the Ni-Cd batteries7</p> <p>LCD and Programming controls8</p> <p>Programming the T6EHAP radio10</p> <p style="padding-left: 20px;">MODL Model select function.....10</p> <p style="padding-left: 40px;">MODL Model select function10</p> <p style="padding-left: 40px">REST Data reset function10</p> <p style="padding-left: 40px">PULS Modulation select function11</p> <p style="padding-left: 60px;">Model name settings.....11</p> <p style="padding-left: 40px">REVE Servo reversing11</p> <p style="padding-left: 20px;">D/R Dual Rate and Exponential settings12</p> <p style="padding-left: 40px">D/R Dual Rate settings12</p> <p style="padding-left: 40px">EXPO Exponentials12</p> <p style="padding-left: 20px">EPA End Point Adjustments.....12</p>	<p>TRIM Trim Settings 13</p> <p>N-TH Normal Throttle Curve 14</p> <p>N-PI Normal Pitch Curve..... 14</p> <p>I-TH Idle-Up Throttle Curve function..... 14</p> <p>I-PI Idle-Up Pitch Curve function 15</p> <p>HOLD Throttle hold function 15</p> <p>REVO Pitch - rudder mixing function 16</p> <p>GYRO Gyro mixing function..... 16</p> <p>SWSH Swashplate types selection & Swash AFR..... 17</p> <p>FS Fail safe (PCM mode only) 19</p> <p style="padding-left: 20px;">Flow chart20</p> <p>Other T6EXHP functions21</p> <p style="padding-left: 20px;">Trainer function21</p> <p style="padding-left: 20px;">Adjustable-length control sticks21</p> <p style="padding-left: 20px;">Changing the stick mode.....22</p> <p>Flying safety guidelines22</p> <p>Flight preparation23</p> <p>Model Data Recording Sheets24</p>
---	--

INTRODUCTION

Thank you for purchasing the Futaba 6EXHP digital proportional R/C helicopter system. If this is your first “computer” radio, rest assured that it is designed to make initial setup and field-tuning of your helicopter easier and more accurate than would be if using a “non-computer” radio. Although this is a **beginner** or **sport** system with the requirements of those flyers in mind, in order to make the best use of your Futaba 6EXHP and to operate it safely, **you must carefully read all of the instructions.**

Suggestion: If, while reading the instructions, you are unclear of some of the procedures or functions and become “stuck,” continue to read on anyway. Often, the function or procedure will be explained again later in a different way providing another perspective from which to understand it. Another suggestion is to connect the battery, switch and servos to the receiver and actually operate the radio on your workbench as you make programming changes. Then, you’ll be able to see the effects of your programming inputs.

SERVICE

(in USA)

If any difficulties are encountered while setting up or operating your system, please consult the instruction manual first. For further assistance you may also refer to your hobby dealer, or contact the Futaba Service Center at the web site, fax number or telephone number below:

www.futaba-rc.com

Fax: (217) 398-7721

Telephone (8:00 am to 5:00 pm Central time Monday through Friday): (217) 398-8970, extension 2

If unable to resolve the problem, pack the system in its original container with a note enclosed and a **thorough, accurate** description of the problem(s). Include the following in your note:

- Symptoms. • Any unusual mounting conditions.
- An inventory of items enclosed. • The items that require repair.
- Your name, address, and telephone number. • Include the warranty card if warranty service is requested.

Send your system to the authorized Futaba R/C Service Center at the address below:

Futaba Service Center
3002 N Apollo Drive Suite 1
Champaign, IL 61822



This product is to be used for sport and recreational flying of radio-control models only. Futaba is not responsible for the results of use of this product by the customer or for any alteration of this product, including modification or incorporation into other devices by third parties. Modification will void any warranty and is done at the owner’s risk.

(USA only)

Protect the environment by disposing of rechargeable batteries responsibly. Throwing rechargeable batteries into the trash or municipal waste system is illegal in some areas. Call 1-800-8-BATTERY for information about Ni-Cd battery recycling in your area.

CONTENTS AND SPECIFICATIONS

Transmitter: T6EXHP

T6EXHP Transmitter with 6-model memory.

Transmitting on 35, 40, 41, or 72 MHz band.

Operating system: 2-stick, 6-channel system

Modulation: FM(PPM) and PCM

Power supply: 9.6V NT8S600B Ni-Cd battery or 12V alkaline battery

Current drain: 250mA

Receiver: R136F

R136F narrow band, FM 6 channel receiver.

Receiving on 35, 40, 41, or 72 MHz band.

Type: FM, Single conversion

Intermediate frequencies: 455kHz, 10.7MHz/455kHz

Power requirement: 4.8V or 6V

Current drain: 9.5mA @ 4.8V

Size: R136F- 1.31x1.98x0.71" (33.4x50.3x18.1mm)

Weight: 0.98oz (27.8g)

Receiver: R127DF

R127DF narrow band, FM 7 channel receiver.

Receiving on 35, 40, 41, or 72 MHz band.

Type: FM, Dual conversion

Intermediate frequencies: 455kHz, 10.7MHz/455kHz

Power requirement: 4.8V or 6V

Current drain: 9.5mA @ 4.8V

Size: 1.39x2.52x0.82" (35.3x64.0x20.8mm)/

Weight: R127DF- 1.5oz (42.5g) / R136F- 0.98oz (27.8g)

Receiver: R138DP

R138DP narrow band, PCM 8 channel receiver.

Receiving on 35, 40, 41, or 72 MHz band.

Type: PCM, Dual conversion

Intermediate frequencies: 455kHz, 10.7MHz/455kHz

Power requirement: 4.8V or 6V

Current drain: 16mA @ 4.8V

Size: 2.56x1.42x0.85" (65.0x36.0x21.5mm)

Weight: 1.42oz (40.3g)

Receiver crystals:

The receiver frequency may be changed as long as it remains within the "low" and "high" band frequency range. If your receiver is on any channel from 11 through 35, it is a "low band" receiver and the frequency may be changed to any other channel from 11 through 35 without having to perform any other service. Simply purchase a crystal on the desired channel, then replace the existing crystal in your receiver with the new one. If your receiver is on any channel from 36 through 60, it is a "high band" receiver and the frequency may be changed to any other channel from 36 through 60. To order a receiver crystal, replace the "***" in the order numbers below with the required channel number. (To order a receiver crystal on channel 30, order FUTL5730.)

FM Dual Conversion 72 MHz **low band** (channels 11 - 35) receiver crystal . FUTL57**

FM Dual Conversion 72 MHz **high band** (channels 36 - 60) receiver crystal . FUTL58**

Note: Should you ever wish to change the transmitter frequency, the transmitter must be sent to the Futaba Service Center for retuning.

Servos: S3001

S3001 standard ball bearing

Control system: Pulse width control, 1.52ms neutral

Power requirement: 4.8 or 6V (from receiver)

Output torque: 44.4oz-in [3.2kg-cm] @ 4.8V

Operating speed: 0.23sec/60° @ 4.8V

Size: 1.59x0.78x1.41" [40.4x19.8x36mm]

Weight: S3004- 1.3oz (37.2g) / S3003- 1.3oz (38.0g)

Servos: S3151

S3151 Digital standard servo with mounting hardware and servo arm assortment

Control system: Pulse width control, 1.52ms neutral

Power requirement: 4.8 (from receiver)

Output torque: 43.1oz-in [3.1kg-cm] @ 4.8V

Operating speed: 0.21sec/60° @ 4.8V

Size: 1.59x0.79x1.42" [40.5x20x36.1mm]

Weight: 1.48oz (42g)

Other components:

Switch harness

Instruction manual

*Specifications and ratings are subject to change without notice

INTRODUCTION TO THE 6EXHP SYSTEM

IMPORTANT! Always turn on the transmitter first, then the receiver. When turning off the system, always turn off the receiver first. The object is never to have the receiver on by itself. Otherwise, the servos or control surfaces could be damaged, or in the case of electric-powered models, the motor may unexpectedly turn on causing severe injury.

IMPORTANT! Never collapse the transmitter antenna by pushing down from the top. If one of the segments becomes momentarily stuck you may damage the antenna. Instead, collapse the antenna from the bottom, drawing in one segment at a time.

Transmitter

Transmits in both FM (PPM) and PCM by selecting modulation/cycling transmitter. Requires receiver of proper modulation. The liquid-crystal display (LCD) on the face of the compact, ergonomically-designed case is easy to read and allows rapid data input. The system also holds independent memories for six different models. The new, adjustable-length control sticks provide an improved feel. Dual rate (D/R), Idle up, Throttle hold, and Gyro sense can be operated by switch. Two different gyro senses can be set with Futaba GY401/502/601 Gyro on gyro function of this transmitter.

Transmitter controls

The diagram and explanations briefly describe the functions of the Futaba T6EXHP transmitter. Full instructions on how to operate the controls are provided beginning on page 10.

NOTE: The diagram shows a Mode 2 system as supplied. (More on flight modes on page 22).

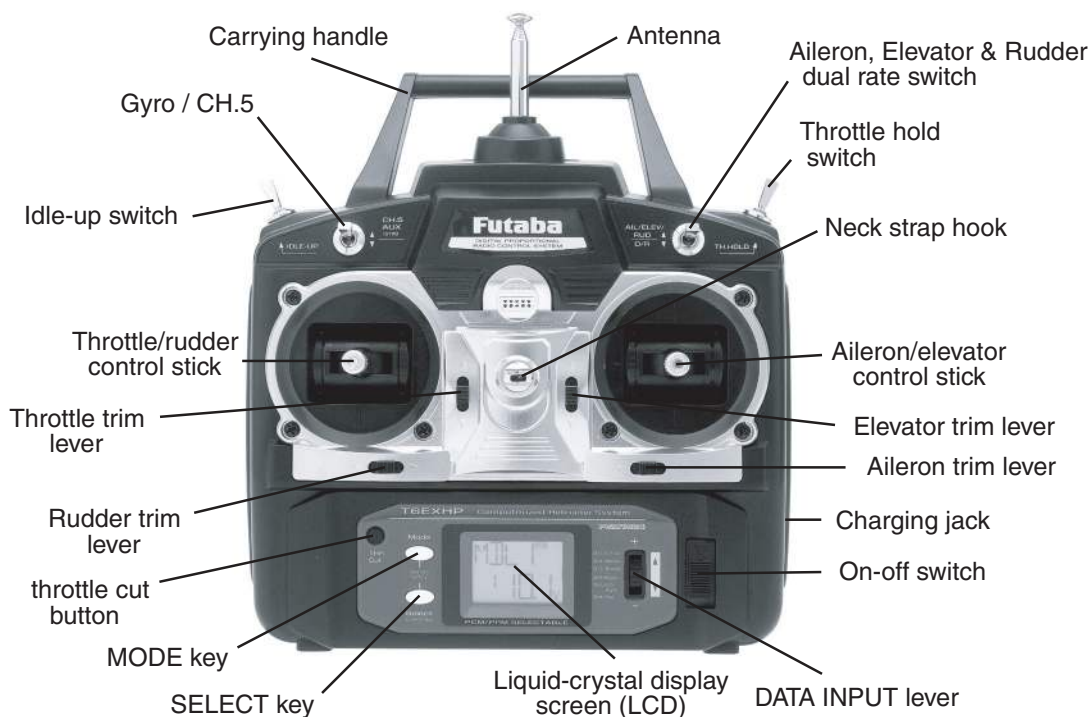

DESCRIPTIONS:

Aileron, Elevator and Rudder dual rate switch -

Use this switch to “flip” between two aileron, elevator and rudder control throw settings. The throws can be set up however you prefer, but generally, when the switch is “up” the throws are greater (“high rate”) and when the switch is “down” the throws are less (“low rate”). This switch also flips between exponential rates (if used).

Throttle – hold switch - This switch operates to hold the engine in the idling position and disengaged it from the Throttle Stick. It is commonly used to practice auto-rotation.

Neck strap hook - Mounting point for optional neck strap.

Aileron/elevator control stick - Operates the servos connected to channel 1 (aileron) and channel 2 (elevator) in the receiver.

Trim levers (all) - Used to shift the neutral or center position of each servo as labeled in the diagram.

NOTE: The throttle trim lever is intended for fine tuning the throttle servo when the engine is at idle. Throttle trim does not affect the throttle servo when the throttle control stick is all the way up (so idle r.p.m. can be adjusted without affecting throttle settings through the rest of the stick movement).

Charging jack - Port for charging the transmitter batteries with the included battery charger. On-off switch

On/off switch

DATA INPUT lever - Used to change the values of the various functions displayed on the LCD screen

Liquid - crystal display screen (LCD) - Displays programming modes and values entered.

MODE key - Used to scroll through and display the "13" or "14"(PCM) different functions.

SELECT key - Used to display the values for the current function.

Throttle – cut button - To use the throttle-cut function, lower the throttle stick all the way, then Push the throttle-cut button to fully close the carburetor and shut of the engine.

Throttle/rudder control stick - Operates the servos connected to channel 3 (throttle) and channel 4 (rudder) in the receiver.

Idle – up switch - This switch operates to change the fight condition which is set the throttle curve and pitch curve of mid air maneuvers (rolls, loops, stall turns) and 3D flight.

Gyro switch/Channel 5 - You can connect the sense adjust connector to the channel 5 of the receiver to operate the gyro which has two different sense. Also if you use Futaba GY401/502/601 Gyro, two different gyro senses setting on gyro function in this transmitter can be call by this switch.

Antenna - Radiates signals to the receiver. Never fly a model without fully extending the antenna or you may create interference to other modelers and decrease operational signal range of the transmitter. The antenna may be removed and replaced with another in case it is inadvertently broken.

RADIO INSTALLATION

Follow these guidelines to properly mount the servos, receiver and battery.

IMPORTANT! Please use PCM receiver if the composition parts of the model used much metal, carbon graphite etc. because they will generates quite a lot of the noise.

- Make certain the **alignment tab** on the battery, switch and servo connectors is oriented correctly and "keys" into the corresponding notch in the receiver or connectors before plugging them in. When unplugging connectors, never pull on the wires. Always pull on the plastic connector instead.
- If any servo wires are not long enough to reach the receiver, servo extension wires (available separately) may be used.
- Always mount the servos with the supplied **rubber grommets**. Do not over tighten the screws. No part of the servo casing should contact the mounting rails, servo tray or any other part of the helicopter structure. Otherwise, vibration will be transmitted to the servo causing premature wear and/or servo failure.

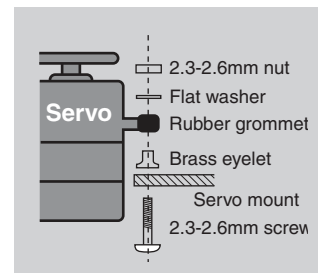

- Note the small numbers (1, 2, 3, 4) molded into each arm on the Futaba 4-arm servo arms. The numbers indicate how many degrees each arm is "off" from 90 degrees to correct for minute manufacturing deviations from servo to servo.

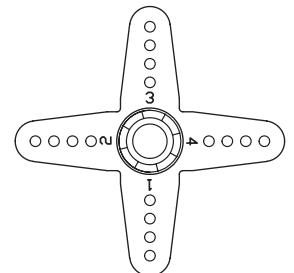

THE TRIMS ON THE RADIO SHOULD BE CENTERED.

- To center the servos, connect them to the receiver and turn on the transmitter and receiver. Center the trims on the transmitter, then find the arm that will be perpendicular to the pushrod when placed on the servo.

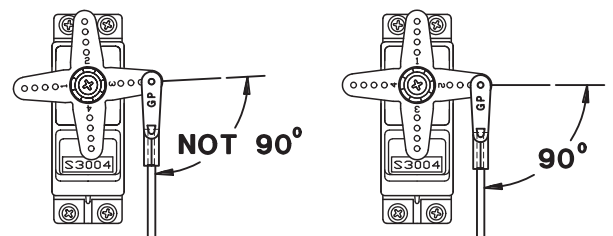

- After the servos are installed, operate each servo over its full travel and check that the pushrods and servo arms do not bind or contact each other. Also make sure the controls do not require excess force to operate. If there is an objectionable buzzing sound coming from a servo, there is probably too much resistance in the control. Find and correct the problem. Even if there is no servo damage, excess battery drain will result.
- When you install the switch harness to the helicopter, please use switch cover. Generally sandwich the frame by switch and switch cover and securely tighten the screws. It might be different installations on model by model. In that case, please follow the model instruction manual.
- **IMPORTANT: NEVER** cut the receiver antenna or mount it in the model folded back on itself. Doing so will change its electrical length, possibly reducing the distance from the pilot that the model can be controlled (“range”).
- The receiver antenna may be mounted inside or outside the model:

Internal antenna mounting:

- You may run the antenna inside of a **non-metallic** housing within the fuselage, but range may suffer if the antenna is located near metal or carbon fiber pushrods or cables. Do not bind the antenna with servos, switch, battery harnesses. Be sure to perform a range check before flying (see page 23).

External antenna mounting:

- Please use rubber grommet or silicon tube to protect from cut or peel off insulation of antenna on the fuselage antenna-exiting hole.

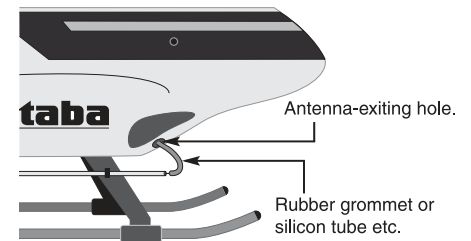

- Place the receiver antenna out from the fuselage part to the nonmetal tube installed in skid etc. Please keep antenna away from parts that made of metal and carbon graphite.

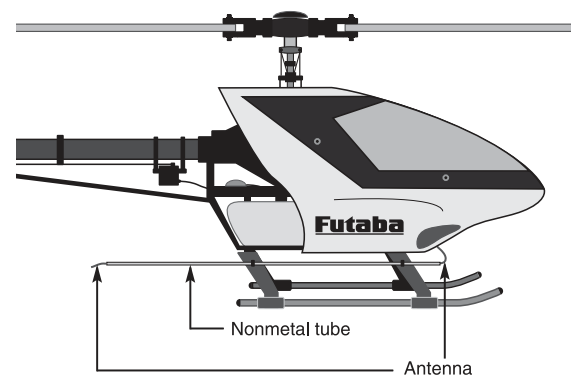

- The receiver contains precision electronic parts. It is the most delicate radio component on-board the model and should be protected from vibration, shock and temperature extremes. To protect the receiver, wrap it in R/C foam rubber or other vibration-absorbing material. If appropriate, waterproof the receiver by placing it in a plastic bag and closing the open end with a rubber band before wrapping it in foam. If moisture enters the receiver, intermittent operation or a failure may result. Wrapping the receiver in a plastic bag also protects it from fuel and exhaust residue which, in some models, can work its way into the fuselage.

Mounting the frequency clip: (for USA)

- To announce your frequency and avoid potential interference problems, the frequency number should always be displayed on the transmitter antenna while flying. Peel the backing from the numbers and apply them to both sides of the clip. Snap the end of the clip that fits best to the base of the antenna as shown. You may cut off the other end of the clip.

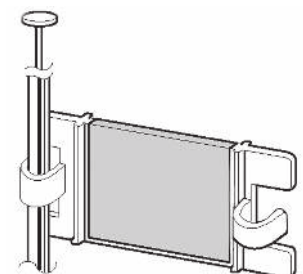

RECEIVER AND SERVO CONNECTIONS

Connect the servos to the receiver to perform the functions indicated:

Receiver output channel	Function
1	Aileron
2	Elevator
3	Throttle
4	Rudder
5	Gyro sensitivity
6	Pitch
7	Not used
B	Receiver on/off switch (the plug colored red goes into the receiver)

The diagram shown is for helicopter models only. It is necessary to buy an additional gyro separately.

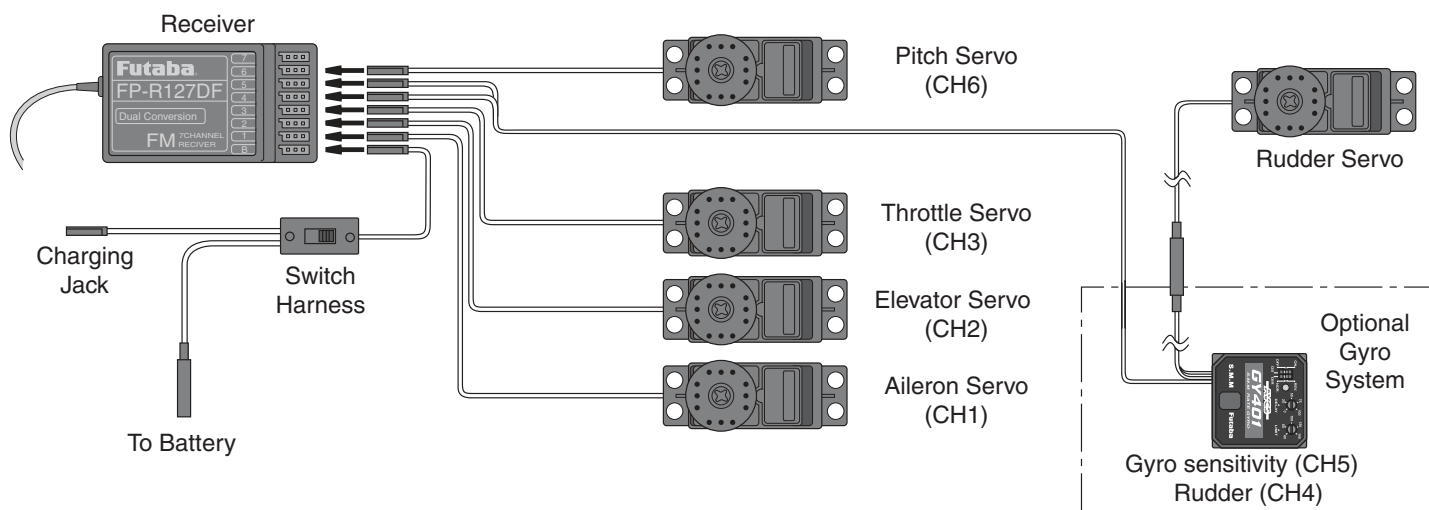

CHARGING THE NI-Cd BATTERIES

The transmitter and receiver batteries included with your 6EXHP system are rechargeable, Ni-Cd (nickel-cadmium, pronounced ni-kad) batteries. Ni-Cd batteries require special care and charging. **Read the charging instructions carefully.**

NOTE: The batteries are supplied partially charged, but will require a full, overnight charge before the model may be flown.

1. Connect the **transmitter charging cord** coming from the A/C wall charger to the charge jack in the right side of the transmitter case. The receiver charging cord may be connected to the batteries two different ways: The charge cord may be connected directly to the battery pack, or to the vacant charge connector (black) coming from the on/off switch in the model. Charging "through the switch" is preferred as there will be no need to disconnect the battery.
2. Plug the A/C wall charger into a wall outlet. **Note:** If the wall outlet can be turned off by a switch in the room, be certain the switch remains on after leaving the room. Otherwise, the batteries will not be charged!
3. The LEDs (light-emitting diodes) should light red, indicating that current is flowing and the batteries are being charged. Discharged batteries will take about 15 hours to fully charge. If using an aftermarket fast charger, **be certain to follow the manufacturer's instructions provided with the charger** so you do not overcharge the batteries. **NEVER** charge the batteries at a rate higher than 1,000mAh. The batteries should also be discharged periodically to prevent a condition

called “memory.” If, for example, only two flights are made each time you go flying, the batteries will not have “reached” very far down into their full capacity. After doing this several times the batteries will “remember” and eventually “think” they can supply only enough power for two flights. After two flights the batteries may not provide enough power to operate the system, thus causing a crash. To erase any potential memory, cycle the batteries by discharging, then charging them with a commercial battery cycler, or leave the system on and exercise the servos by moving the transmitter sticks until the servos are moving very slowly, indicating that the battery is discharged. Cycling should be done every one to two months, even during the winter or periods of long storage. If using a cycler with a readout, note the capacity after the batteries have been cycled. If there is a noticeable drop in capacity the batteries should be replaced.

Note: Charging your batteries with the included Futaba A/C battery charger is always safe. However, fast-charging with an aftermarket charger is acceptable as long as you know how to properly operate the charger. **NEVER** charge at a rate higher than 1,000 mAh (1 Amp). If not done correctly, fast-charging can damage the batteries.

LIQUID CHIP DISPLAY (LCD) & PROGRAMMING CONTROLS

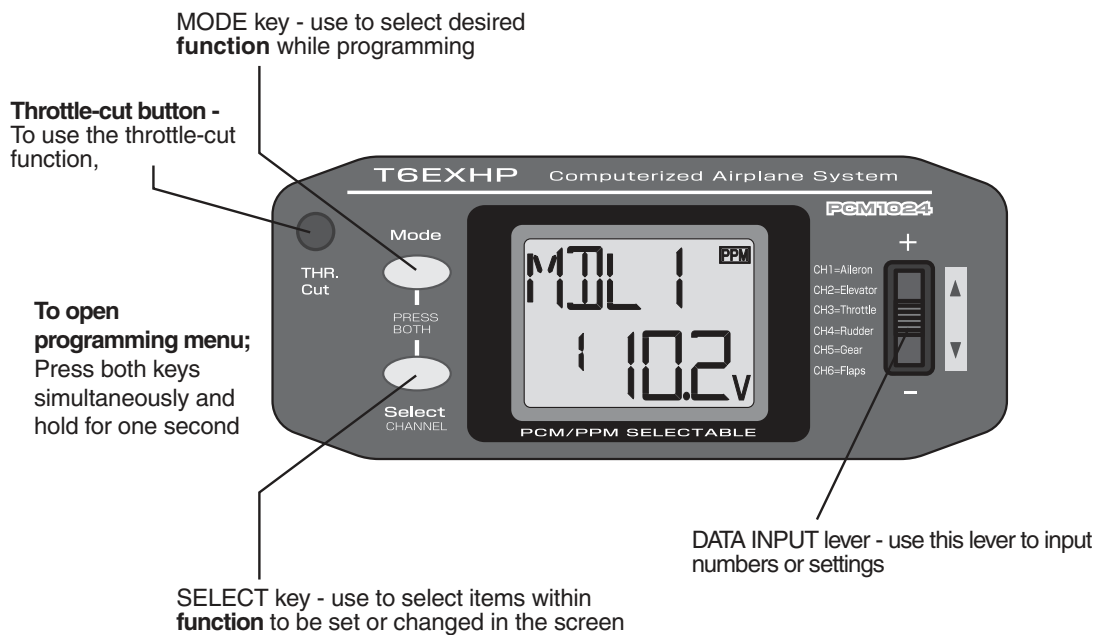

LCD display screen

When the transmitter is **Initially** turned on, the **model memory number, model memory name, modulation type** and **transmitter battery voltage** are displayed on the LCD screen. When prompted by the user, the functions and settings stored in the memory can also be read on the screen. The user accesses the different functions using the MODE and SELECT keys and changes the values and settings using the DATA INPUT lever. (This is called programming!)

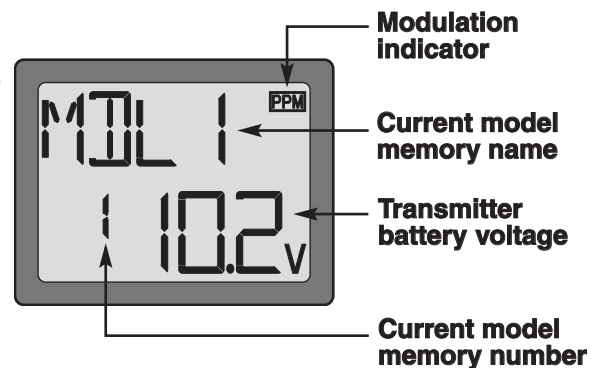

Note: Feel free to explore by scrolling through the programs and viewing the displays using the MODE and SELECT keys. The MODE and SELECT keys only determine what will be displayed on the screen and will not change any of the settings. Only when using the DATA INPUT lever will you be able to change any of the settings.

Model memory number and model name

The Futaba T6EXHP stores model memories for six models. This means all the data (control throws, trims, end points, etc.) for up to six different models can be stored in the transmitter and activated at any time (depending upon which model you choose to fly that day). This eliminates the requirement for reconfiguring the transmitter each time you decide to fly a different model with it! When the transmitter is turned on the **model number, model name, modulation** and the **transmitter voltage** will be indicated on the LCD screen. Before every flight **BE CERTAIN** that the correct model number for the model you intend to fly appears on the screen. If the transmitter is not operating the correct model, some (or all) of the controls could be reversed and the travels and trims will be wrong.

Flying a model with the wrong program will result in a crash, so always **be certain** the model number and model name in the transmitter is correct. One way to ensure this is to write the corresponding model number directly on the helicopter, or attach a list to the bottom or back of the transmitter.

Transmitter battery voltage

In addition to the model number, the LCD screen also displays the **transmitter battery voltage**. When the voltage goes below approximately **8.5 Volts** the “battery” icon will **flash** and the low-battery alarm will continuously beep until the transmitter is turned off. When the low-battery alarm sounds you will have approximately four minutes (or less) to land your model before losing control. You should never allow the transmitter voltage to become this low while flying, but if it does, land **immediately**.

“Battery” icon

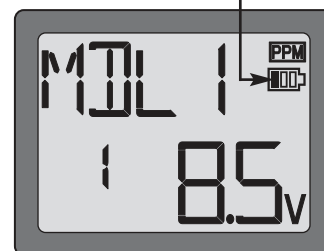

Note: When the transmitter voltage reads **8.9 Volts** you will still have approximately ten minutes (or less) before losing operational range, so this is the recommended **absolute minimum** voltage. If the transmitter ever reaches 8.9 Volts, land as soon as safely possible. A more reasonable margin of safety would be to quit flying for the day (or recharge the batteries) when the transmitter battery.

SUGGESTED GUIDELINES

- 9.4 Volts - No more flying until recharge.
- 8.9 Volts - Land as soon as safely possible.
- 8.5 Volts - **Emergency- Land immediately!**

Mixer alert warning

The **Mixer alert** warning is displayed to alert you whenever you turn on the transmitter with any of the mixing switches active. This warning will disappear when the offending switch or control is deactivated. Switches for which warnings will be issued at power-up are Throttle hold switch or Idle-up switch.



Backup error

The **Backup error** warning occurs when the transmitter memory is lost for any reason. If this occurs, all of the data will be reset when the power is turned on again.

When the Backup error occurs, initialization starts from model number 6 to 1.

The model number on the left of the screen changes from 6 to 5, to 4, to 3, to 2, to 1, and finally the number disappears. The disappearance of the model number indicates that the initialization has been completed. Now you can turn off the power of the transmitter. Please do NOT turn off the power during the initialization; otherwise initialization will restart when you turn on the power.

Do not fly when this message is displayed: all programming has been erased and is not available. Return your transmitter to Futaba service.



PROGRAMMING THE 6EXHP RADIO

Anytime you wish to **view** or **change** any of the current settings in the transmitter, the programming mode must first be entered by, of course, turning on the power, then by pressing the **“MODE”** and **“SELECT”** keys simultaneously and holding them down for one second. Once in the program the MODE key will be used to scroll through each of the “13” or “14” (PCM) functions (model number/ data reset/ modulation select/ model name, reversing, dual rates/ exponentials, end point adjustments, trim, normal throttle curve, normal pitch curve, idle-up throttle curve, idle-up pitch curve, throttle hold, revolution mixing, gyro sensitivity, swashplate types, and failsafe) and the SELECT key will be used to view the settings within the function. When a data change is actually required the **“DATA INPUT”** lever will be used to increase or decrease the value of the item displayed, thus making the change.

You can return to the home screen (where the model number and battery voltage is displayed) by pressing the MODE and SELECT keys simultaneously and holding them down for one second.

Note: The functions are listed and described in the order that they appear in the transmitter. Read all the way through the programming instructions before setting up your model (if you won't be using any of the mixing functions for a while you can read those instructions when ready). Refer to the FLOW CHART on page 20 as well.

Model Select / Data Reset / Modulation Select / Model Name

MODL Model select function

To select model memory:

1. Access the Model Select function in the programming mode (by pressing the MODE and SELECT keys simultaneously and holding them down for one second). The number for the current, active model will be blinking.
2. To activate a different model memory press the DATA INPUT lever until the desired model number appears.
3. Now the model has been selected. All programming inputs from this point forward will affect only the model number on the screen (until another model number is selected).

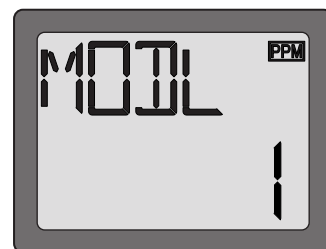

REST Data reset function

All the data for any model memory can be reset to the original factory defaults. Often this function is done to get a “fresh start” and clear the memory before inputting new model settings.

To reset data:

1. Access the Model Select function in the programming mode (by pressing the MODE and SELECT keys simultaneously and holding them down for one second). Use the DATA INPUT lever to select the model memory you wish to reset.
2. Once the desired model number is displayed on the screen, press the SELECT key. A **“REST”** will appear on the screen.
3. Push DATA INPUT upward or downward for about 2 seconds to clear and reset the memory. **“CLR”** blinks first, and then it stops blinking with a sound. Now the model data is reset to the initial setting that is the default value set at the factory.



The existing modulation and swashplate type settings are not reset. If the power switch is turned off while reset is underway, the data may not be reset.

CAUTION: Resetting the current model memory will permanently erase **ALL** programming information for that model. The data cannot be recovered (unless you recorded it on a Model Data Recording Sheet in the back of this manual). Do not reset the model unless you are certain you want to clear-out that memory and start from scratch.

When actually setting up a model you should have the model in front of you with the power on so you can actually see the effects of your programming inputs and measure the control throws.

PULS Modulation select function

The Modulation select function is used to select the **PPM** or **PCM** mode of transmission, to match the receiver being used (PPM-Pulse Position Modulation, also called FM for Frequency Modulation, and PCM-Pulse Code Modulation).

To select modulation:

1. Access the Model Select function in the programming mode (by pressing the MODE and SELECT keys simultaneously and holding them down for one second). Use the DATA INPUT lever to select the model memory you wish to modulation select.
2. Push SELECT key twice after seeing on the screen the model memory where you want to set modulation, then you will see "PULS" on the screen.
3. To select PCM modulation, push the DATA INPUT lever up. The "**PCM**" is displayed. To select PPM modulation, push the DATA INPUT lever down. The "**PPM**" is displayed.
4. To get the transmitter to operate in the new mode, switch transmitter power off and then on. The small indicator will indicate the mode, either PPM or PCM.

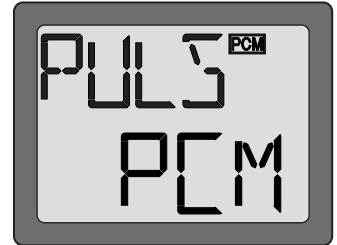
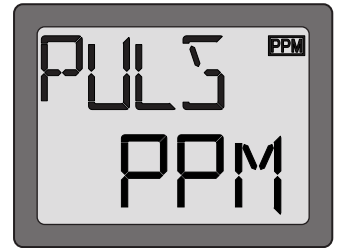

Model name function

Assign a name to the model memory. By giving each model a name that is immediately recognizable, you can quickly select the correct model, and minimize the chance of flying wrong model memory that could lead crash.

1. Access the Model Select function in the programming mode (by pressing the MODE and SELECT keys simultaneously and holding them down for one second). Use the DATA INPUT lever to select the model number you wish to change.
2. Push SELECT key three times after seeing on the screen the model memory where you want to set the model name, then you will see the model name on the screen.
3. Choose a character for the first digit by using DATA INPUT lever. Then move to the next digit by pressing the SELECT key and choose a character in the same way. Continue choosing characters for the third and fourth digits. You can use up to four characters for the name.

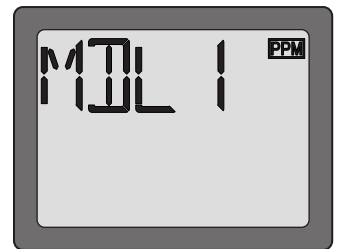

REVR Servo Reversing

The servo reversing function is used to change the direction that a servo responds to a control input from the transmitter (stick or switch). After using the reversing function, check **all** the controls on the model to **be certain** they are operating in the correct direction and that you did not inadvertently reverse a servo other than the one intended. Reversing the wrong servo (and not checking the response of the controls before each flight) may be the most common cause of a crash!

To reverse a servo:

1. Enter the programming mode and use the MODE key to access the **REVR** function.
2. Use the SELECT key to select the channel you wish to reverse.
3. Push the DATA INPUT lever downward to reverse the servo (REV), or push the lever upward to make the servo operate normally (NOR). The arrow will indicate the condition of the servo (normal or reversed).
4. Use the SELECT key to display other channels to be reversed.



Dual Rates / Exponential Settings

The aileron, elevator and rudder dual rates on the 6EXHP are simultaneously activated by the dual rate switch. The amount of travel decrease for each control may be set between 0% and 100% of the values set for the end points (explained in End Point Adjustment on page 12).

Note: It is possible to set a dual rate value to zero, thus causing no response from that channel. If the dual rates are inadvertently set to zero, a crash could result.

Note: When performing initial model setup, the E.P.A.s should be set **prior to** setting the dual rates. When setting the E.P.A.s for the first time on a new model, the dual rates should be set to 100%.

D/R Dual Rate Settings

To set the dual rates:

1. Enter the programming mode. Access the “**D/R**” screen with the MODE key.
2. Select the channel to be adjusted (1-aileron, 2-elevator, 4-rudder) by pressing the SELECT key until the desired channel number the left side on the screen. Note: If a “**EXPO**” will appear on the screen, you have pressed the SELECT key too many times and displayed the values for the exponentials (explained later). Press the SELECT key to return to the dual rate values.
3. Place the dual rate switch in the desired position for the value you wish to change. (Generally, pilots prefer to have the switch in the “up” position for the high rate, and in the “down” position for the low rate.)
4. Change the dual rate value using the DATA INPUT lever until the desired control throw is achieved. If you wish to change the control throw when the switch is in the other position as well, flip the switch, then use the DATA INPUT lever to change the throw.
5. Repeat the procedure for the other dual rate (channel 2-elevator, 4-rudder).

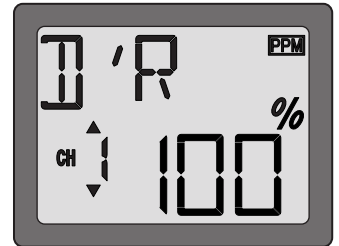

EXPO Exponential Settings

The “exponentials” are in the same function as the dual rates. (Pressing the MODE key will take you to the next function which is End Point Adjustments). The same as dual rates, “expos” can be set for both switch positions. Negative exponential (-) decreases initial servo movement. Positive exponential (+) increases initial servo movement. The exponential “curve” may be set anywhere between -100% and +100%.

To set the exponentials:

1. Enter the programming mode. Access the “**D/R**” screen with the MODE key.
2. Access the “**EXPO**” screen with the SELECT key.
3. Select the channel (1-aileron, 2-elevator, 4-rudder) you wish to set by pressing the SELECT key. The active channel number will be displayed on the screen Note: If a “D/R” will appear on the screen, you have pressed the SELECT key too many times and displayed the values for the D/R (dual rate values). Press the SELECT key to return to the exponentials.
4. Position the dual rate switch where desired for the value you wish to change.
5. Enter the amount of exponential with the DATA INPUT lever. (As stated above, an exponential value with a “-” in front of it makes the initial servo movement less, or “softer.”)
6. Flip the switch to the other position to enter the exponential value for that switch position.
7. Repeat for the settings on the other channel.

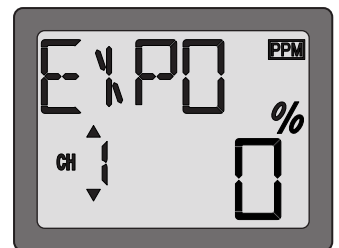

EPA End Point Adjustment

Note: Since changing the “end points” will also change the dual rates, the end points should be set prior to setting the dual rates. If you set the dual rates first, and then go back and change the end points, the dual rate throws will also change.

The EPA function is designed to “fine tune” the servo throws in cases where changing the pushrod hookup will not achieve the

correct throw. The pushrods should first be connected to the servo arms and control horns so that the correct, or near correct control surface throw will be achieved. THEN the EPAs may be used to make small changes in the servo throw until the desired control throw is achieved. The control throws should be set up so that the “end points” are as near to 100% as possible. If the EPA values must be set below 70% or above 120% to get the desired throw, you should strongly consider changing the pushrod connections so the values can be set closer to 100%. (When the EPA is set to 100% the maximum servo throw for channels 1, 2, 3 & 4 is approximately 40° and approximately 55° for channels 5 & 6.)

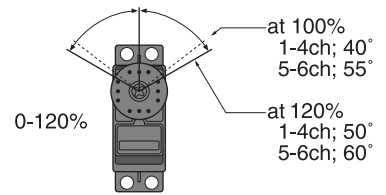

To set the end points:

1. Enter the programming mode and use the MODE key to access the “EPA” screen. The channel number being adjusted will be on the left side on the screen and the “%” symbol will be flashing.
2. To change the RIGHT aileron throw move the aileron stick to the right, then push the DATA INPUT lever up or down to change the value and the throw.
3. Move the stick to the left and use the DATA INPUT lever to change the LEFT aileron throw.
4. Use the SELECT key to display the other channels and set the other end points. Notice that moving the stick (or switch or dial) from one end to the other changes the value displayed and the position of the arrow for that “end” of the control input.

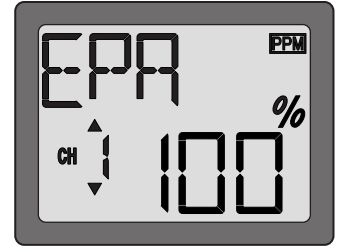

TRIM Trim Settings

There are four trim levers (“trims”) on the front of the transmitter. Three of the trims are for adjusting the neutral position of the aileron, elevator and rudder servos. The fourth trim is for setting the idle r.p.m. of the engine when the throttle stick is all the way down. The intended use of the trims is to make small servo adjustments, in flight, to get the model properly “trimmed” (so it will fly straight-and-level). Because the trims are intended to be used while the model is in flight, you do not have to “enter the program” to adjust the trims. Simply push or pull on the trim levers while flying and the neutral position of the servos will shift. Keep in mind that you should start out with the control surfaces centered when the servos are centered and the trims are “zeroed” (or near zero). **THEN** you can adjust the trims once airborne.

Center the servos:

1. Turn on the transmitter and receiver. Operate the controls to make sure the servos respond in the correct direction. Use the reversing function to reverse any servos necessary.
2. Center the throttle control stick.
3. Place the servo arms on the servos so they are perpendicular to the pushrods (see page 5). It is okay to cut off any unused servo arms.
4. Connect the pushrods to the control surfaces. Adjust the length of the pushrods until the control surfaces are centered when the servos are centered.

Note: The throttle trim affects the throttle servo only when the throttle stick is below “1/2 stick.” This way, the final closing of the carburetor can be adjusted without affecting the servo throughout the rest of the range.

To adjust the trim settings:

Once the servos and control surfaces have been connected and the control throws have been set using the end points and dual rates, get the model airborne. Adjust the trims as necessary to get the model to fly straight-and-level. If much trim is required on any one control it is a good idea to readjust the pushrods so the trims can be returned to neutral (zero). Adjusting the trims with the trim levers changes the servo’s position in increments of “4.” If finer adjustments are required, land the model, then enter the program as described below to adjust the trims in increments of “1.”

1. Enter the programming mode and use the MODE key to activate the TRIM menu.
2. Press the SELECT key to display the channel to be adjusted (the figure shows trim adjustment for CH1).
3. Adjust the trim using the DATA INPUT lever. Note that initially, the values change in increments of “1,”but if the DATA INPUT lever is held long enough the values will change more rapidly.
4. Repeat the steps for other channels that require trim adjustments.

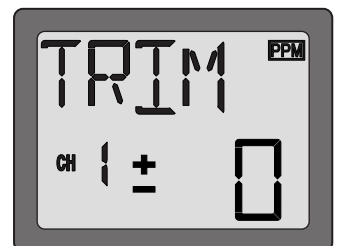

N-TH Normal throttle curve function

Used to set throttle curve for normal flight. 5-point throttle curve is utilized to best match the blade collective pitch to the engine RPM for consistent load on the engine. Throttle curve can be adjust from 0-100% each point.

This normal throttle curve create basic curve for around hovering. Use this function together with the normal pitch curve (see Normal pitch curve) so that up/down control has a constant engine speed.

To set the normal throttle curve:

1. Enter the programming mode and use the MODE key to access the “N-TH” function. Throttle stick position number will appears on left side of display and “%” symbol will be flashing.
2. Use SELECT key to select the desire curve point. Point 1 is shown initially which is throttle stick all the way downward (slow) position. Point 5 is throttle stick all the way upward (hi) position.
3. Push up or down DATA INPUT lever to set the servo position.
4. Use SELECT key to set other points with same manner.

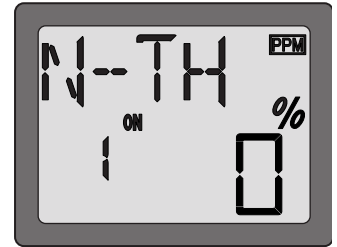

N-PI Normal pitch curve function

Used to set pitch curve for normal flight. 5-point pitch curve is utilized to best match the blade collective pitch to the engine RPM for consistent load on the engine. Pitch curve can be adjust from 0-100% each point.

This normal pitch curve create basic curve for around hovering. Use this function together with the normal throttle curve so that up/down control has a constant engine speed.

To set the normal pitch curve:

1. Enter the programming mode and use the MODE key to access the “N-PI” function. Throttle stick position number will appears on left side of display and “%” symbol will be flashing.
2. Use SELECT key to select the desire curve point. Point 1 is shown initially which is throttle stick all the way downward (slow) position. Point 5 is throttle stick all the way upward (hi) position.
3. Push up or down DATA INPUT lever to set the servo position.
4. Use SELECT key to set other points with same manner.

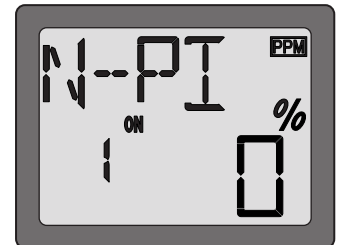

I-TH Idle-up throttle curve function

Used to set throttle curve for idle up flight. 5-point throttle curve is utilized to best match the blade collective pitch to the engine RPM for consistent load on the engine when idle up function is on. Throttle curve can be adjust from 0-100% each point.

This idle up throttle curve is to set for consistent engine RPM and can be activated at any time when mid air maneuvers are executed, such as loops, rolls, and 3D flight even when reduced the blade collective pitch.

To set the idle-up throttle curve:

1. Enter the programming mode and use the MODE key to access the “I-TH” function.

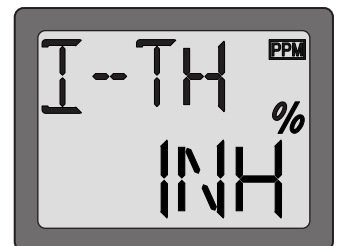

2. Push the DATA INPUT lever upward. This will cause the flashing “INH” display to change to a flashing “ON” display. Now the I-TH function is on. Push the SELECT key, throttle stick position number will appears on left side of display and “%” is blinks.

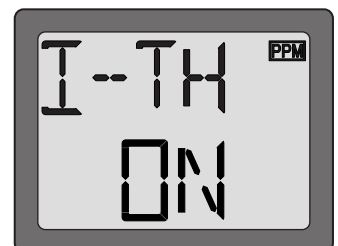

- Use SELECT key to select the desire curve point. Point 1 is shown initially which is throttles stick all the way downward (slow) position. Point 5 is throttles stick all the way upward (hi) position.
- Push up or down DATA INPUT lever to set the servo position.
- Use SELECT key to set other points with same manner.

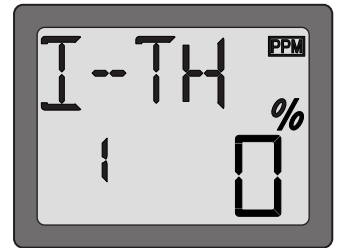

I-PI Idle-up pitch curve function:

Used to set pitch curve for idle up flight. 5-point pitch curve is utilized to best match the blade collective pitch to the consistent engine RPM when idle up is used. Pitch curve can be adjust from 0-100% each point.

The high side pitch curve should be set to not to over load the engine and keep consistent engine RPM. Generally set less pitch than normal maximum pitch. The low side pitch curve is to set for desired maneuver such as loops, rolls, and 3D flight.

To set the idle-up pitch curve:

- Enter the programming mode and use the MODE key to access the "I-PI" function.
- Push the DATA INPUT lever upward. This will cause the flashing "INH" display to change to a flashing "ON" display. Now the I-TH function is on. Throttle stick position number will appears on left side of display and "%" symbol will be flashing.



This function cannot be used when "I-TH" function is not activated. When you set "I-PI" function, you mast activates "I-TH" function.

- Use SELECT key to select the desire curve point. Point 1 is shown initially which is throttles stick all the way downward (slow) position. Point 5 is throttles stick all the way upward (hi) position.
- Push up or down DATA INPUT lever to set the servo position.
- Use SELECT key to set other points with same manner.

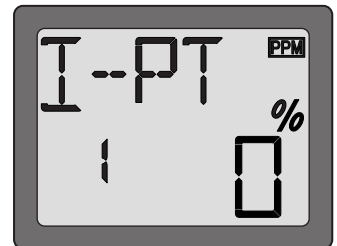

HOLD Throttle hold function

Throttle hold function is to be used for autorotations where only pitch control is used to make a descent and landing. Just flip the hold switch on to set the engine in the idling or cut position and disengaged it from the Throttle Stick. It can be set from (-)50 to (+)50% from throttle trim position.

To set the throttle hold:

- Enter the programming mode and use the MODE key to access the "HOLD" function.
- Push the DATA INPUT lever upward. This will cause the flashing "INH" display to change to a flashing "ON" display. Now the "HOLD" function is on.



- Push SELECT key once. This will cause the flashing "%" symbol on the display. Pull the hold switch fowards you. Push up or down DATA INPUT lever to set the throttle servo position of throttle hold.

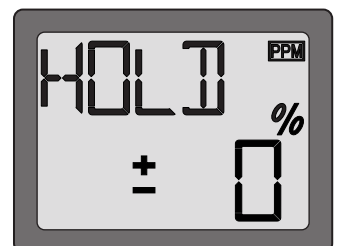

REVO Pitch-rudder mixing function

This mix adds rudder in conjunction with pitch. This helps compensate for rotation of the helicopter caused by the increased engine torque. (Never use revo. mixing with a heading-hold/AVCS gyro which is in heading hold/AVCS mode. However, revo. mixing is still used when a heading-hold/AVCS gyro is in normal mode.)

To set the REVO mixing:

1. Enter the programming mode and use the MODE key to access the “REVO” function.

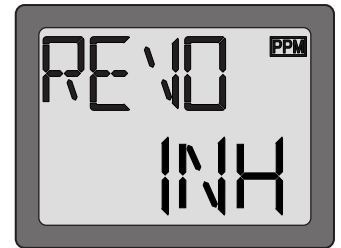

2. Push the DATA INPUT lever upward. This will cause the flashing “INH” display to change to a flashing “ON” display. Now the “REVO” function is on.



3. Push the SELECT key once. This will cause the flashing “%” symbol on the display. It can be set mixing amount on throttle stick hi side and low side separately. When you move the throttle stick to the low side from neutral, the arrow indicates down direction and then push up or down DATA INPUT lever to set the mixing amount of the low side. When you move the throttle stick to the high side from neutral, the arrow indicates up direction and then push up or down DATA INPUT lever to set the mixing amount of the low side.

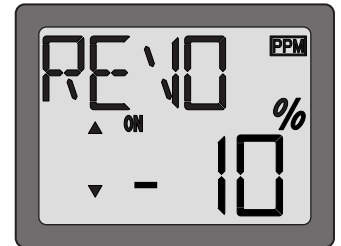

GYRO Gyro mixing function

GYROS : Using electronics to take some of the complexity out of setups and flight.

What is a gyro? A gyroscope is an electronic unit that senses motion and corrects for it. For example, if the wind blows your helicopters tail to the left, a gyro will sense that motion (and confirm that no input was given) and will correct for it.

How does it help in helicopter setup? A good gyro will totally eliminate the need for revo. mixing. The gyro will sense and correct the unwanted motion for you, so you don't have to spend time to get a complex curve operating properly.

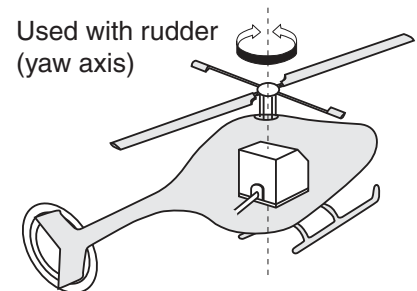

Gyro sensor kinds: There are many different kinds of gyros. Early gyros were mechanical, with a spinning drum similar to a child's gyroscope toy. The next generation utilized a special type of crystal, called piezoelectric, which sensed the motion and provided an electrical pulse. The finest gyros at the time of this writing are SMM technology. These silicone micro machines, or computer chips, sense the motion. SMM is far more accurate and less susceptible to inaccuracies caused by temperature changes, etc.

Choosing the right gyro for your skills, your helicopter, and your budget:

- Mechanical: some are still available. They are very challenging to set up and not as reliable as piezo or SMM.
- Non-Heading-Hold Piezo: these are now inexpensive gyros that are reliable and easy to set up. Some have dual rates and remote gain control to adjust sensitivity in flight. Lack heading-hold capabilities for precision flying.
- Heading-Hold Piezo: Until recently, the cream of the crop. Expensive, and more complex to set up. Adds GPS-like heading recognition. Exhibits minor difficulties with temperature drift (position setting varying with unit's temperature).

- Heading-Hold SMM: 21st Century gyro technology. Computer chip technology. Expensive, easier set up, higher durability. Significant decrease in temperature sensitivity. Many include frame rate settings to allow faster response when using specialized digital servos. Examples:
 - **GY401**: Simpler set up. Ideal for learning aerobatics through 3D.
 - **GY502**: Better centering than 401 for more advanced aerobatics. Ideal through Class III competition.
 - **GY601**: Exceptional center. Extremely fast response time. Requires specialized servo.

Gyro mixing function is use for adjusting the gain of the gyro and selecting the gain from two different gain settings by switch on the transmitter with the gyro that can set two different gains witch placed on the model.

To set the GYRO mixing:

1. Plug the gyro’s sensitivity adjustment to channel 5 of the receiver. (not assignable)
2. EPA of channel 5 (see page 12-13) to set 100% both UP and DOWN.
3. Enter the programming mode and use the MODE key to access the **“GYRO”** function.

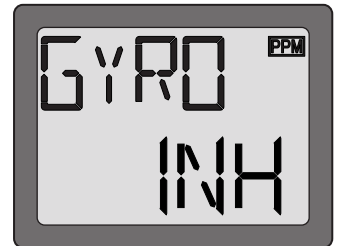

4. Push the DATA INPUT lever upward. This will cause the flashing **“INH”** display to change to a flashing **“ON”** display. Now the mixing is on.



5. Push the SELECT key once. This will show the gyro gain setting and flashing **“%”** symbol on the display.

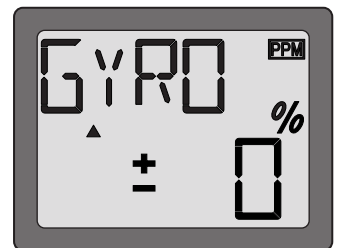

Flip the gyro (CH5) switch up and down. This will cause the arrow points up and down on the display simultaneously with switching operation and show the position of the switch. Push up or down DATA INPUT lever to set the gyro gains both switch up and down position. Gyro gain can be adjust from -100% to +100%.

Example of sensitivity setting with GY401

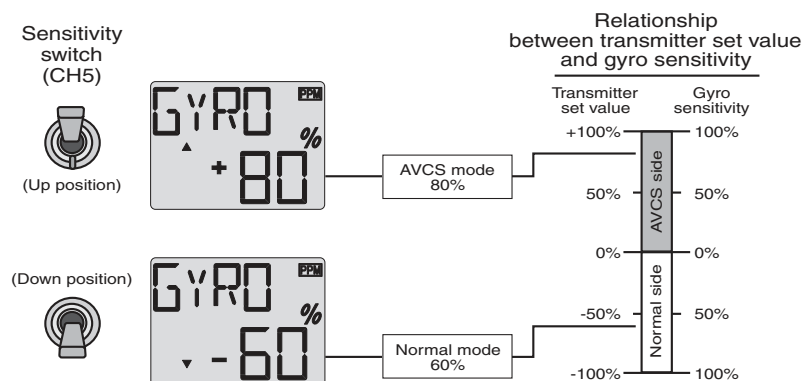

SWSH Swashplate types selection & Swash AFR

This function can choose from two swashplate types. Swash AFR can be set, if you choose 3-S type

1-S: Independent aileron, pitch and elevator servos linked to the swashplate. Most kits are 1-S type.

3-S: With Aileron inputs, the aileron and pitch servos tilt the swashplate left and right; with Elevator inputs, the three servos tilt the swashplate fore and aft; with Pitch inputs, all three servos raise the swashplate up and down.

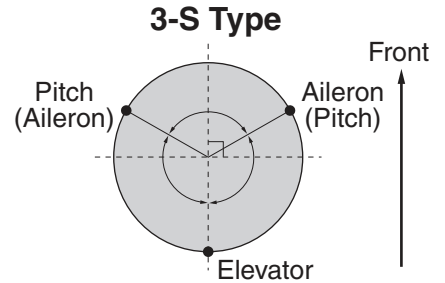

To select the swashplate types:

1. Enter the programming mode and use the MODE key to access the **“SWSH”** function.
2. Use DATA INPUT lever to select swashplate type. When you want to choose **“1-S”** type, move upward with DATA INPUT lever. When you want to choose **“3-S”** type, move downward with DATA INPUT lever. When you are changing swashplate type to 1-S, or 3-S, the 1-S, or 3-S on the display flashes slow to change rapid and then stop flashing to show 1-S, or 3-S solid with confirmation sound.
3. Now it set the swashplate type.

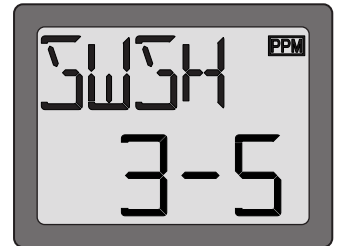
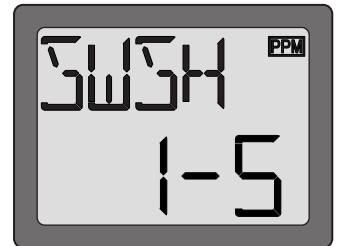

To set the swash AFR:

This function only can set when you selected the 3-S swashplate type. There is no swash AFR setting with 1-S type. This swash AFR function is to use for change the direction and amount of servo movement on aileron, elevator, and pitch.

At first, linkage and set the servo horn length on aileron, elevator, and pitch servos follow by instruction manual comes with the model. Basically **“EPA”** (see page12) is set near 100% with these three servos. To set the servo **“reverses”** function (see page11) so that swashplate keeps horizontally and moves correct direction up and down by operating pitch control (up and down throttle stick).

1. Enter the programming mode and use the MODE key to access the **“SWSH”** function.
2. Swashplate types, Confirm 3-S type is selected. If 3-S type is not selected, please see **“To select the swashplate types”** and set.
3. Use select key to select the channel you wanted to set. Aileron channel **“CHA”** is displayed at first and **“%”** is flashing.
Move the aileron stick left and right to set the direction and amount of movement on the aileron servo by push up or down DATA INPUT lever. Aileron movement can be adjust from -100% to +100% .
4. Other channel (elevator and pitch) select by SELECT key to set the direction of movement and movement amount of servo with same manner of aileron channel setting.
“CHE” is elevator and **“CHP”** is pitch channel on the Display.

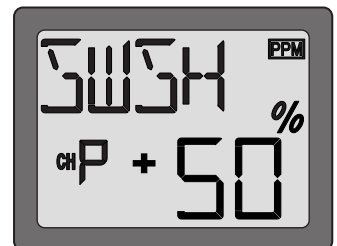
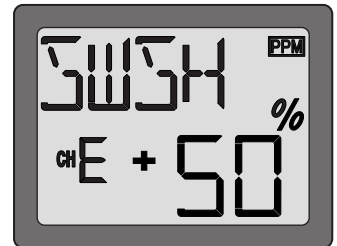
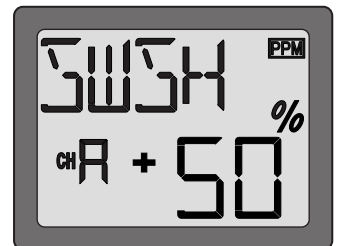

F/S Fail Safe (PCM mode only)

The Fail Safe function is used to prescribe what the PCM receiver will do in the event radio interference is received, and doesn't work FM(PPM) receivers. In this menu, you may select from one of two options of operation for each channel. The "NOR"(normal) setting holds the servo in its last commanded position, while the "F/S"(Fail Safe) function moves each servo to a predetermined position.

Throttle channel is set to "F/S" as a default. All the other channels are set to "**NOR**".

The use of the failsafe function is recommended from the standpoint of safety. You may wish to set the throttle channel so that the throttle is moved to idle when there's interference. This may give enough warning to allow you to fly towards yourself and recover from the radio interference. If you choose to specify a failsafe setting, the failsafe data are automatically transmitted once each minute.

Battery Failsafe

Your system provides a second safety function called Battery Failsafe. When the airborne battery voltage drops below approximately 3.8V, the battery fail safe function moves the throttle to a predetermined position or fast idle, if you haven't set it. If this happens, you should immediately land! If you need to increase throttle for your landing approach, you may temporarily reset the failsafe function by moving the throttle stick to idle, after which you'll have about 30 seconds of throttle control before the battery function reactivates.

To set the Fail Safe Function:

1. Enter the programming mode. Access the "**F/S**" screen with the MODE key.
2. You can find the channel blinking on the left of the screen, which can be set to the Fail Safe. The first channel you see is CH1 (aileron). Press DATA Input lever downward when you need to set Fail Safe. The arrow moves to "F/S" side. This means this channel has been set to F/S function. Then move the aileron stick to the position where you want the servo to move when "**F/S**" function works and press DATA INPUT lever downward for about two seconds while holding the stick. A figure in percentage will be shown with a beeping sound. Press DATA INPUT lever upward if you want to set "**NOR**". The arrow moves to "NOR" side and then this channel will be set to "**NOR**" function.
3. Carry out similar procedure like this in setting "F/S" function for other channels. Use Mode key to show a channel and do the same. But, CH3 (throttle) is set to 20% of the full throttle for "F/S" function as a default.

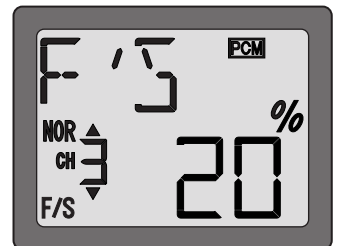
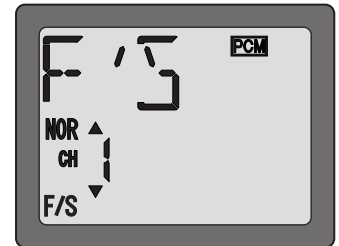

4. Verify that your failsafe programming works by switching off transmitter power and observing the motion of the servos.

FLOW CHART 6EXHP FUNCTIONS

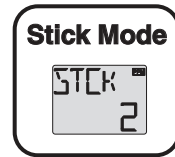
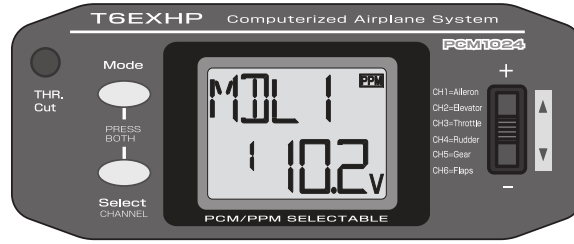

(Screen at Startup)

To enter or leave Programming Mode, press MODE and SELECT keys simultaneously for one second.

To change the Stick Mode, turn on the transmitter holding MODE and SELECT keys down simultaneously. Use the DATA INPUT lever to display the desired stick mode.

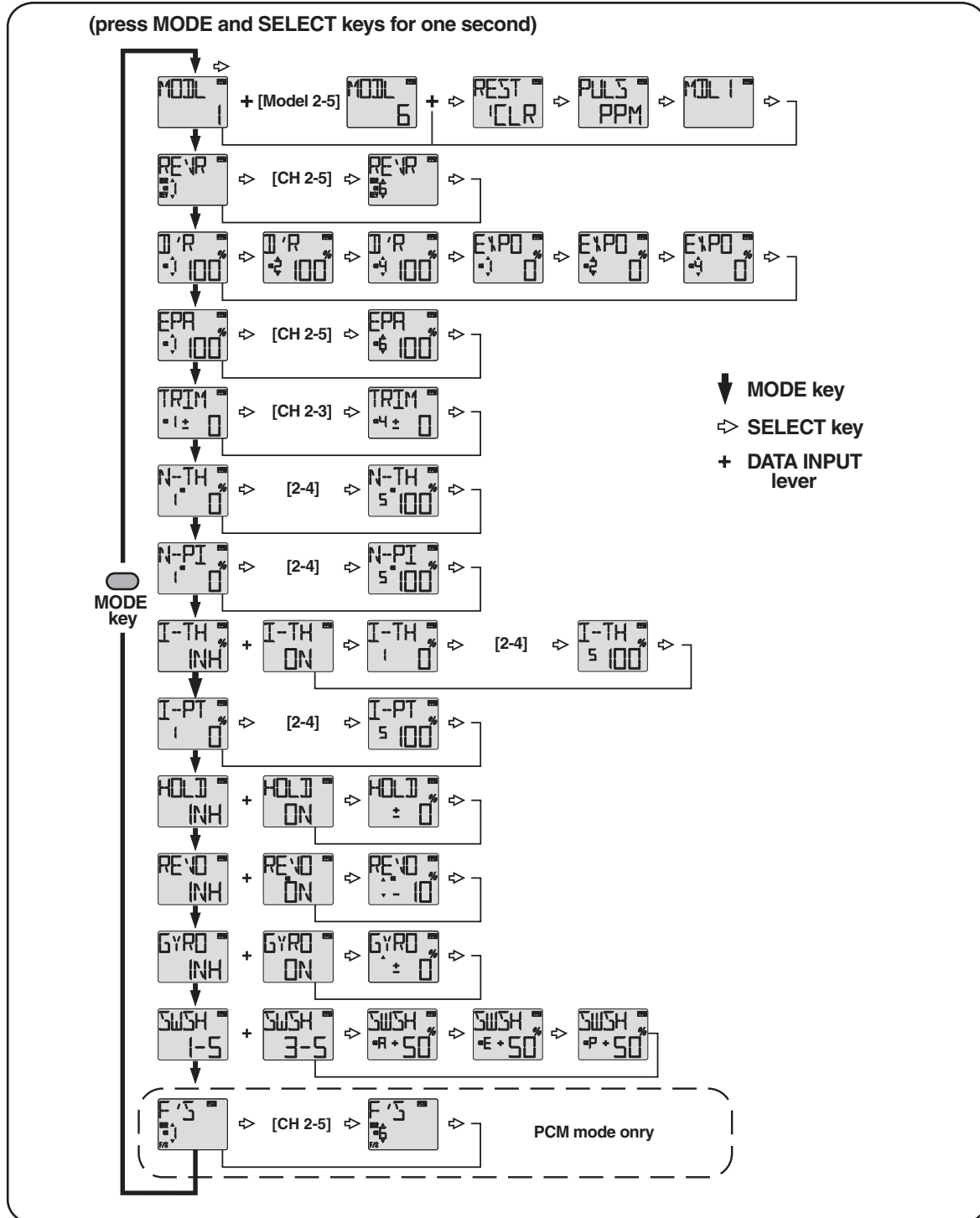

Simultaneously Press the **“MODE”** and **“SELECT”** keys and hold them down for one second to enter the programming mode. Press the keys again (or turn off the transmitter) to exit the programming mode.

OTHER 6EXHP FUNCTIONS

Trainer function (*student only*)

The T6EXHP trainer function lets you practice flying as student by connecting the T6EXHP to the instructor's Futaba transmitter. When two radios are connected with the trainer cord, they are both capable of operating the model, but it's usually best for the instructor to hold the radio that has been setup for the plane to be flown (as it is already programmed to fly the model). When the instructor holds the trainer switch on his radio, the student will have control. When the instructor wishes to regain control he simply releases the switch. Then he will have immediate, full control.

If connecting the 6EXHP to the T7CHP, T9CHP or 14MZ with the small, square "micro" trainer jack, use the "Micro to Micro" (MM-TC) trainer cord (FUTM4415). If connecting the 6EXHP to Futaba radios with the larger, round, "DIN" connector, use "Micro to DIN" (MD-TC) trainer cord (FUTM4420).

Corresponding types of transmitters for helicopter: T6X, T7U, T7C, T8U, T9C, T9Z, T14MZ

To use the trainer function:

1. It is best for the instructor to use the transmitter that is already set up for the model to be flown.
2. Set your T6EXHP (student 's radio) to the follow modulation mode; If the instructor uses the T7C, T8U, T9C, T9Z or T14MZ, set your radio to PPM. If other Futaba radio, set the mode of your radio to match the mode of the instructor's.
3. Collapse the student's antenna and fully extend the instructor's antenna.
4. With the transmitters off, connect the trainer cord to both radios. (On the 6EXHP the trainer jack is in the center of the rear of the case.) Do not force the plug into the transmitter and note that the plug is "keyed" so it can go in only one way.
5. Turn on the instructor's transmitter. **DO NOT** turn on the student's transmitter it will automatically "power up," but will not transmit a signal. Set the servo reversing and trims of the student's radio to match that of the instructor's.
6. Turn on the receiver switch in the model. Depress the trainer switch on the instructor's radio. Use the student's radio to operate the controls (ailerons, elevator, rudder, etc.) and observe how they respond. Make any adjustments necessary to the student's transmitter to get the controls to respond correctly.
7. Check to see that the trims are in "sync" by toggling the trainer switch back and forth a few times. The controls on the model should remain stationary. If the controls do not remain stationary, this indicates that the trim settings on the student's radio do not match those on the instructor's radio. Adjust the student's trims as necessary.



Throttle-cut function

The throttle-cut function is intended to be used for shutting off the engine. The engine can be conveniently shut off by pressing the "THR Cut" button. The throttle-cut feature prevents inadvertently shutting off of the engine when lowering the throttle stick all the way (such as when coming in for a landing). Throttle-cut works only when the throttle stick is down. To set up throttle-cut, turn on the transmitter and receiver. Actuate the throttle-cut function by rapidly depressing, then releasing the switch twice. Observe the momentary position of the carburetor barrel on the engine. It should be fully closed (thus shutting off the engine). If necessary, use the throttle E.P.A. (channel 3) to fully close the carburetor barrel when the throttle-cut is activated. Now use the throttle trim to open the carburetor barrel so the engine will idle at the desired R.P.M. when the throttle stick is all the way down.

Adjustable-length control sticks

The control stick length is adjustable to make the transmitter more comfortable to hold and operate. To adjust the length, hold the **locking piece (B)** and turn the **stick tip (A)** counterclockwise. Turn the locking piece B up or down to lengthen or shorten the stick. When the length is suitable, lock the stick in position by turning locking piece B counterclockwise.

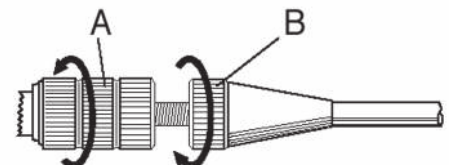

Changing the 6EXHP stick mode

The transmitter may be operated in four different stick “modes” (1, 2, 3 & 4). The modes determine the functions that will be operated by control sticks. Currently, the transmitter is in “mode 2” and should be left in mode 2 unless you are an experienced flyer and have learned to fly in a different mode. In mode 2, the right control stick operates the aileron and elevator and the left stick operates the rudder and throttle. This is how 99% of Americans fly their models.



To change the mode, simultaneously depress the MODE and SELECT keys, then turn on the power. The current mode will appear on the LCD screen. Push the DATA INPUT lever up or down to change the mode. If a mode is selected that moves the throttle control to the right stick, **the throttle detent mechanism will have to be moved as well.** This can be done by the Futaba Service Center. (See page 2)

FLYING SAFETY GUIDELINES

Find a suitable flying site (for USA)

If you are a beginning modeler and not yet a member of an R/C club, joining a club and flying at a site specifically intended for R/C model aircraft is highly recommended. In addition to joining a club, we strongly recommend joining the AMA (Academy of Model Aeronautics). AMA membership is required to fly at AMA clubs. There are over 2,500 AMA-chartered clubs across the country. Among other benefits, the AMA provides insurance to its members who fly at sanctioned sites and events. Additionally, training programs and instructors are available at AMA club sites to help you get started the right way. Contact the AMA at the address or toll-free phone number below:

I. If you must fly in wet weather during a contest, be sure to cover the transmitter with a plastic bag or other waterproof cover.

Academy of Model Aeronautics

5151 East Memorial Drive
Muncie, IN 47302-9252
Tele. (800) 435-9262
Fax (765) 741-0057

Or via the Internet at: <http://www.modelaircraft.org>



IMPORTANT:

If you do insist on flying on your own, you must be aware of your proximity to R/C club sites. If there is an R/C site within six miles of where you are flying, and if you are operating your model on the same frequency as somebody else, there is a strong possibility that one or both models will crash due to radio interference. There is great potential for an out-of-control model to cause property damage and/or severe personal injury. We strongly urge you to fly at an R/C club site where frequency control is in effect so you can be confident you will be the only one flying on your channel.

Charge the batteries

Second to the pilot's flight skills, one of the most important factors that can determine a model's longevity is the state-of-charge of the batteries - especially the on-board receiver pack. Inadequate charging and failing to monitor a battery's voltage may lead to low battery power, causing loss of control and a crash. To avoid this, always charge the batteries the night before you go flying. If ever uncertain how much “charge” is left in a battery, it is wiser to err on the side of caution, rather than trying to get in one last flight! Due to the number of factors that determine receiver battery power consumption (such as the number and type of servos in your model, the type of flying you do, how much resistance is built into the controls, the size of the model, etc.), it is not possible to recommend how many flights one can get on a charge. The best way to monitor battery power and calculate how much flight time you have left is to use a volt meter to check the batteries after each flight. This can be done through the battery charging plug coming from the switch. There are many small, hand-held volt meters available specially intended for R/C use. The Hobbico® Digital Voltmeter MKIII™ (HCAP0356) is one such unit. An on-board volt meter mounted directly on the model (HCAP0330) can also be used.

FLIGHT PREPARATION

Flight preparation is to be done at the flying field.

IMPORTANT: Your radio control system transmits a signal on a certain frequency. Be certain you know what the frequency is. This is expressed as a two-digit number (42, 56, etc.), and can be found on the container the transmitter came in and is also located on the transmitter and receiver. There are several different frequencies, but there is still a chance that someone else at the flying field may be on the same frequency as you. Two models can never be operated at the same time on the same frequency-no matter what the modulation (AM, FM, PCM). If you turn on your transmitter while another person is flying on the same frequency, a crash will result. **NEVER** turn on your transmitter until you have permission from your instructor, and until you have possession of the frequency clip used for frequency control at the flying site.

If you are an inexperienced pilot, be certain your flight instructor performs these following checks with you.

Check the controls

1. Get the frequency clip from the frequency control board at your flying site.
2. Mount the wing to the fuselage. Turn on the transmitter, then the receiver (remember to do this in reverse order when turning off the system). Be certain the correct model memory matching the model you will be flying is the one on the LCD screen.
3. Operate and observe the controls. Look for inadvertent movement and listen for abnormal servo sounds. If problems are noted, correct them before flying. Look for binding pushrods or servo arms or pushrods that interfere with each other.
4. One at a time, operate each control on the airplane using the sticks on the transmitter to make certain each control is responding correctly. This **must** be done before **every** flight. (There are several types of malfunctions that can be discovered by performing this elementary task, thus saving your model!)

Range check the radio

A range check **must** be performed before the **first** flight of a new model. It is not necessary to do a range check before every flight (but is not a bad idea to perform a range check before the first flight of each day). A range check is the final opportunity to reveal any radio malfunctions, and to be certain the system has adequate operational range.

1. Turn on the transmitter, then the receiver. Leave the transmitter antenna all the way down. Walk away from the model while simultaneously operating the controls. Have an assistant stand by the model and signal what the controls are doing to confirm that they operate correctly. You should be able to walk approximately 20 - 30 paces from the model without losing control or seeing "litter" in the servos.
2. If everything operates correctly, return to the model. Set the transmitter in a safe, yet accessible location so it will be within reach after starting the engine. Be certain the throttle stick is all the way **down**, then start the engine. Perform another range check with your assistant holding the plane and the engine running at various speeds. If the servos jitter or move inadvertently, there may be a problem. **Do not fly** the plane! Look for loose servo connections or binding pushrods. Also be certain you are the only one on your frequency, and that the battery has been fully charged.
3. When ready to fly, remember to fully extend the transmitter antenna. Avoid pointing the antenna directly at the model as the signal is weakest in that direction.

Do not fly in the rain!

Moisture may enter the transmitter through the antenna or stick openings and cause erratic operation or loss of control. If you must fly in wet weather during a contest, be sure to cover the transmitter with a plastic bag or other waterproof cover.

MODEL DATA RECORDING SHEET

After finalizing the programming for each model, fill out the values and settings in the **Model Data Recording Sheets** in the back of the manual. The data sheets will serve as a backup in case a program is ever lost or inadvertently reset, or in case you have to intentionally reset a program to make room for another model. Make additional copies before filling out the sheets.

MODEL DATA RECORDING SHEET

(Make copies before using)

Model name: _____

Model No. 1 • 2 • 3 • 4 • 5 • 6

MENU FUNCTION		CH 1	CH 2	CH 3	CH 4	CH 5	CH 6
REVR	Servo Reverse	N • R	N • R	N • R	N • R	N • R	N • R
D/R	Dual Rate setting	▲ %	▲ %		▲ %		
		▼ %	▼ %		▼ %		
EPA	End Point Adjust	▲ %	▲ %	▲ %	▲ %	▲ %	▲ %
		▼ %	▼ %	▼ %	▼ %	▼ %	▼ %
TRIM	Trims						
EXPO	Exponential setting	▲ %	▲ %		▲ %		
		▼ %	▼ %		▼ %		
F/S	Failsafe (PCM Only)	%	%	%	%	%	%

MIXING SETTING

N-TH	Normal Throttle Curves		P-1 ____ % P-2 ____ % P-3 ____ % P-4 ____ % P-5 ____ %
N-PI	Normal Pitch Curves		P-1 ____ % P-2 ____ % P-3 ____ % P-4 ____ % P-5 ____ %
I-TH	Idle-UP Throttle Curves	INH • ON	P-1 ____ % P-2 ____ % P-3 ____ % P-4 ____ % P-5 ____ %
I-PI	Idle-UP Pitch Curves	INH • ON	P-1 ____ % P-2 ____ % P-3 ____ % P-4 ____ % P-5 ____ %
HOLD	Throttle Hold	INH • ON	Throttle hold position ± ____ %
REVO	Pitch- Rudder Mixing	INH • ON	▼ ± ____ % ▲ ± ____ %
GYRO	Gyro Mixing	INH • ON	▼ ± ____ % ▲ ± ____ %
SWSH	Swashplate Types	1-S • 3-S	CH A (Aileron) ± ____ % CH E (Elevator) ± ____ % CH P (Pitch) ± ____ %