

Confirmation of F/S operation

After switching HOLD ⇄ CH3-F/S mode, check the fail-safe operation by following the procedure below.

- 1 Gas-powered models with the engine stopped. For electric airplanes, the propeller is removed from the motor. For electric helicopters, the pinion gear is removed from the power motor to ensure that the rotor does not rotate.
- 2 Turn on the transmitter and receiver.
- 3 Wait at least 5 seconds after turning on the transmitter or linking.
- 4 Turn off only the transmitter.
- 5 For gas-powered models, check whether the throttle servo reaches the set slow position; for electric models, check whether the motor stops.

⚠️WARNING

❶ When setting and checking the operation of the F/S, stop the engine for gasoline models and keep the propellers and rotors from rotating for electric models. Sudden rotation of propellers and rotors may cause injury.

Range Check the Radio

For safe use, always perform a distance test before flying. The TM-18 has a power-down mode (low power mode) dedicated to distance testing.

The distance test method below is for the case where the 2.4GHz Dual RX Link system receiver on page 3 is connected as an example.

Alternately test both the **Futaba AdRCSS 900MHz** system and the **Futaba 2.4GHz** system.

1 Turn on the transmitter and receiver and ensure that both the **Futaba AdRCSS 900MHz** and the **Futaba 2.4GHz** systems are working correctly.

2 <Futaba AdRCSS 900MHz system distance test>
Keep the receiver side ON, turn the transmitter OFF once, and turn the transmitter ON again without outputting 2.4GHz radio waves. Press the **tact switch of TM-18** for about 10 seconds. The LED will flash red/green simultaneously and will be transmitted in a power-down mode for about 90 seconds. The LED returns to solid green. (2.4GHz is off, and 900MHz is in the power-down mode)

* For information on how to turn on the power without emitting radio waves, please refer to the instruction manual section "Settings without emitting radio waves" section for each transmitter. For the T12K, turn on the transmitter power while pressing RTN, and select "RF OFF" on the power mode switching screen.

* Please note that if you turn on the transmitter while pressing the **tact switch of TM-18**, no radio waves will no emit from **TM-18**.

* If you press the tact switch of TM-18 again while the power-down mode is running, the power-down mode will be extended for about 90 seconds.

3 Move away from the plane while operating the stick in a power-down mode. Move away from the model while using the stick in the power-down mode. Have your assistant check that all controls are working correctly at a distance of about 30-50 steps from the plane.

4 At this time, if the servo moves differently from the operation, there may be some problems. Do not fly until the cause is eliminated. In addition, check the looseness of the servo connection and the linkage condition. Also, use a fully charged battery.

5 <Futaba 2.4GHz system distance test>

Turn off the transmitter's power while leaving the receiver's power on.

©Copyright 2023. No part of this manual may be reproduced in any form without prior permission. The contents of this manual are subject to change without prior notice. While this manual has been carefully written, there may be inadvertent errors or omissions. Please contact our service center if you feel that any corrections or clarifications should be made. Futaba is not responsible for the use of this product.

FUTABA CORPORATION

Hobby Radio Control Business Center Sales & Marketing Department 1080 Yabutsuka, Chosei-mura, Chosei-gun, Chiba-ken, 299-4395, Japan

TEL: +81-475-32-6051, FAX: +81-475-32-2915



Percentage of Waste Paper pulp 80%

6 While pressing the tact switch of **TM-18**, please turn on the transmitter and make it in a state where the **900MHz** radio wave is not emitted. Set the transmitter to range check mode. Do a distance test as well as **900MHz**. (Only **2.4GHz** radio waves are emitted)

7 After completing the distance test, please turn off the transmitter and turn it on as usual. (Both **2.4GHz** and **900MHz** are ON)

⚠️WARNING

❶ Distance test with engine off for gas-powered models. For electric airplanes, remove the propeller from the power motor. For electric helicopters, drag the pinion gear from the power motor so that the rotor does not rotate.

Other Precautions

❶ The **TM-18** antenna is fixed with screws 1, 2, and 3, shown below. If these parts come loose, you may lose control and crash. Check for looseness before turning on the transmitter.

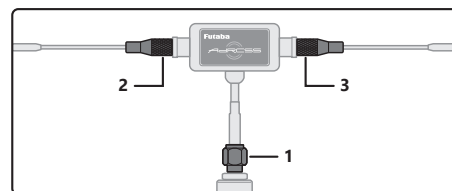

❶ When using a transmitter equipped with **TM-18** on the teacher side of the trainer function, do not switch the trainer switch after turning on the transmitter and before the receiver side becomes operable. Doing so may cause malfunction.

* When using the **TM-18** with the **T12K**, the trainer cable cannot be connected, so the trainer function cannot be used.

For safety's sake, pay special attention whenever you see the marks shown here.

Symbol	Explanation
	Indicates a procedure which could lead to a dangerous situation and may cause death or serious injury if ignored and not performed properly.
	Indicates procedures which may lead to dangerous situations and could cause death or serious injury as well as superficial injury and physical damage.
	Indicates procedures that may not cause serious injury, but could lead to physical damage.

[Symbol] ; Prohibited ; Mandatory

Compliance Information Statement (for U.S.A.)

This device, trade name Futaba Corporation, model number R9001SB, complies with part15 of the FCC Rules. Operation is subject to the following two conditions:

- (1) This device may not cause harmful interference, and
- (2) This device must accept any interference received, including interference that may cause undesired operation.

CAUTION: To assure continued FCC compliance

1. Any changes or modifications not expressly approved by the grantee of this device could void the user's authority to operate the equipment.
2. This equipment complies with FCC radiation exposure limits set forth for an uncontrolled environment. This equipment should be installed and operated with minimum distance 20cm between the radiator & your body. The responsible party of this device compliance is: FUTABA Corporation of America 2681 Wall Triana Hwy Huntsville, AL 35824, U.S.A. Phone:1-256-461-9399 FAX:1-256-461-1059 E-mail: service@futabaUSA.com

Compliance Information Statement (for Canada)

This device complies with Industry Canada license-exempt RSS standard(s). Operation is subject to the following two conditions: (1) this device may not cause interference, and (2) this device must accept any interference, including interference that may cause undesired operation of the device. This equipment complies with IC radiation exposure limits set forth for an uncontrolled environment. This equipment should be installed and operated with minimum distance 20cm between the radiator & your body.

French: Cet appareil radio est conforme au CNR-210 d'Industrie Canada. L'utilisation de ce dispositif est autorisée seulement aux deux conditions suivantes : (1) il ne doit pas produire de brouillage, et (2) l'utilisateur du dispositif doit être prêt à accepter tout brouillage radioélectrique reçu, même si ce brouillage est susceptible de compromettre le fonctionnement du dispositif. Cet équipement est conforme aux limites d'exposition aux rayonnements IC établies pour un environnement non contrôlé. Cet équipement doit être installé et utilisé avec un minimum de 20 cm de distance entre la source de rayonnement et votre corps.

Futaba

1M23N39005

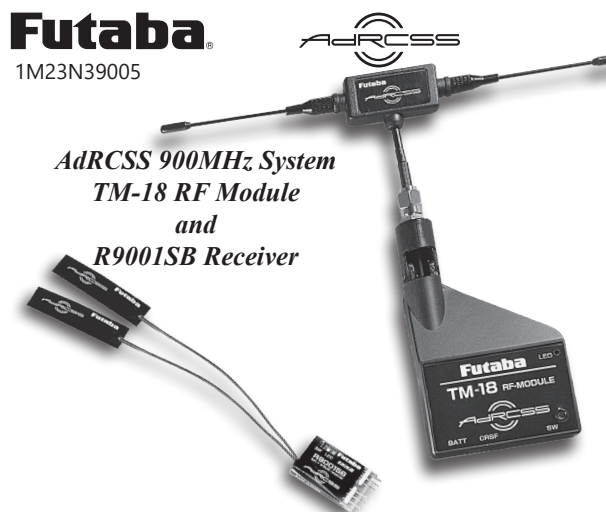

AdRCSS 900MHz System
TM-18 RF Module
and
R9001SB Receiver

Instruction Manual

Applicable systems:

T16IZ, T16IZS, T18SZ, T32MZ

(No dedicated power supply required)

T12K, T16SZ (Requires dedicated power supply)

Features

- Exclusive ID code to avoid interference from other AdRCSS 900MHz systems.
- Fail Safe (F/S) function (for throttle channel)

Recommendation

- It is recommended to use Futaba AdRCSS 900MHz system and Futaba 2.4GHz system at the same time using Dual RX Link System receiver (main = 2.4GHz system)

TM-18 RF Module/R9001SB Receiver

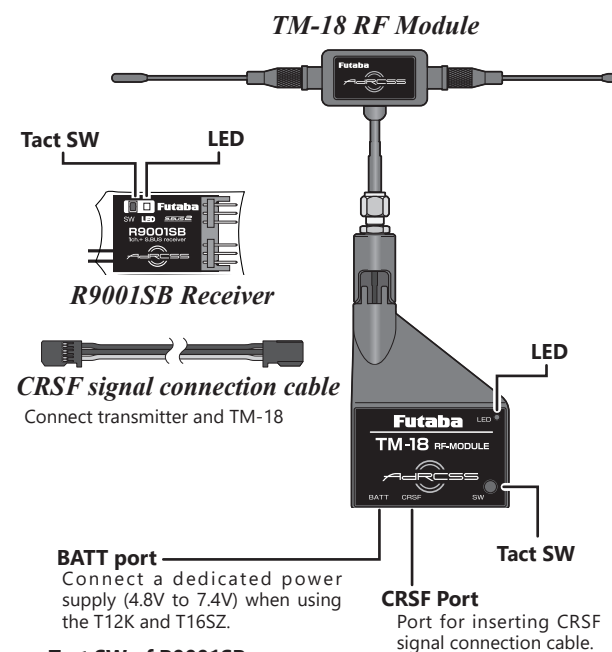

•Tact SW of R9001SB

Used for S.BUS mode change and F/S setting.

•Tact switch of TM-18 RF module

Used for linking with the receiver and a power-down mode.

Important: The AdRCSS 900MHz band offers different characteristics than that of the conventional 50MHz, 72MHz and 2.4GHz. As such, we strongly encourage you to read this manual carefully prior to utilizing the TM-18 RF and R9001SB system.

Thank you for purchasing the AdRCSS 900MHz system TM-18 RF transmitter module and R9001SB receiver. This system is available only with the Futaba transmitters listed left side in this page. The receiver R9001SB is capable of controlling models up to 16 channels. Please install the R9001SB carefully according to the manual.

* AdRCSS stands for Advanced Radio Control System for Sub-GHz band. Shows Futaba 900MHz products.

Usage Precautions:

⚠️WARNING

❶ Before utilizing any radio control system, it is strongly recommended that you read and abide by the Safety Code created by the Academy of Model Aeronautics and any site-specific rules and regulations that might exist. Doing so will significantly increase your enjoyment of the hobby.

❶ To maintain complete control of your aircraft, it must always remain visible. Flying behind large objects, such as buildings, grain bins, etc., is not suggested. Doing so may result in the reduction of the quality of the radio frequency linked to the model.

❶ Please do not grasp the transmitter module's antenna during flight, and doing so may degrade the quality of the radio frequency transmission.

❶ If there're any noise or other RF devices at same 900MHz band, the link of AdRCSS might be degraded. Always check your control is being kept and if any symptom of loss of control felt please stop using immediately.

❶ Do not allow other transmitters, mobile phones, or wireless devices to contact or come close to the TM-18 during operation. Doing so may cause malfunction.

❶ Do not point the tip of the antenna toward the aircraft during flight. (Radio waves are maximized in the lateral direction of the antenna.)

Specifications:

TM-18 RF Module

- Communication system: one-way communication
- Compatible with all Futaba systems (FASTest, FASST MULTI/7CH, S-FHSS, T-FHSS) Two-way communication (telemetry) is not supported.
- Current consumption: 36mA maximum
- Setting switch for LINK and range check

[R9001SB Receiver]

- Dual antenna diversity
- Power requirement: 4.8V-7.4V Dry batteries cannot be used
- Fail Safe (F/S) function (for throttle channel)
- Size: 1.48x0.83x0.21 in (37.5x21.1x5.3mm)
- Weight: 0.16 oz. (4.6g)

* Be sure that when using ESC's regulated output the capacity of the ESC must meet your usage condition. Never use dry cell batteries for the R9001SB receiver as this may cause difficulties with the receiver's operation.

* The amount of maximum channels for S.BUS/S.BUS2 output depends on the transmitter. (Unused CH will be neutral output.) Also, at F/S, the F/S setting CH will be at the F/S position, and other than that will be in the Hold state.

⚠️WARNING

❶ Do not press the tact SW during the flight as the module will be in range check mode so that the RF power will be lowered and will result in fatal crash.

Installing the TM-18 RF Module and R9001SB Receiver

Attachment of the Module

CAUTION

Be sure to turn off the transmitter's power before installing the module.

1 Install the TM-18 with the transmitter powered off.

* As shown in the figure, attach the included double-sided tape, and connect the CRSF port of the TM-18 and the S.I/F connector of the transmitter with the CRSF signal connection cable. (Example: T161Z)

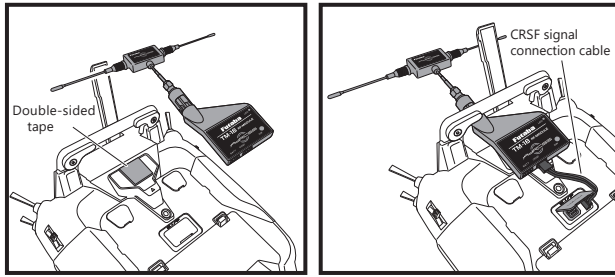

* In the case of T32MZ, attach the included mounting parts and double-sided tape as shown in the figure.

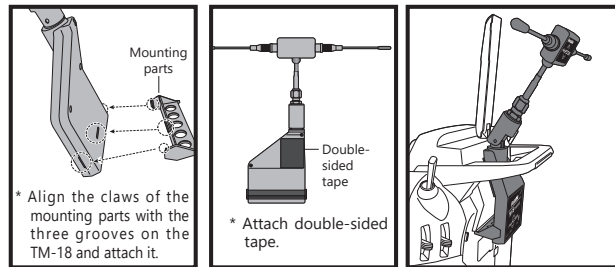

* Connect between TM-18 and the transmitter via CRSF connection cable which come with this set. For T32MZ, use CRSF port. For T161Z(S), T18SZ, and T12K, use S.I/F port.

2 Turn on the power switch of the transmitter. At first, the TM-18's LED is off. Turn on the CRSF function of the transmitter. (Refer to the instruction manual of the transmitter for how to set the CRSF function. The T32MZ has the CRSF function as standard.) The TM-18 LED lights up in red and then turns green.

About module antenna

The antenna has directivity. The strength of the radio wave is maximum in the lateral direction of the antenna and minimum in the tip direction of the antenna. Therefore please do not point the antenna's tip to the aircraft as much as possible.

* Please keep both antenna of TM18 and 2.4GHz's away each other as far as possible.

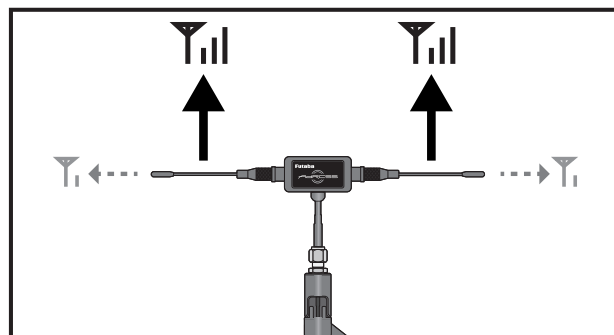

WARNING

Never hold the antenna during flight. Also, do not attach conductive objects such as metal to the antenna.

* Cannot be controlled due to lower transmission output.

How to Link

Each TM-18 RF transmitter module has an individually assigned unique ID code, and the receiver must be linked to the respective TM-18's ID code to start the operation. Once the linking is done, the ID code is stored in the receiver, and re-linking is unnecessary unless the receiver is to be used with a different TM-18 RF module. Additionally, it is essential to note that the factory has already linked this TM-18 and R9001SB receiver set. Should you wish to re-link them, or if you have purchased a separate receiver and would like to link it to this TM-18, please adhere to the following procedure.

WARNING

Do not perform linking while the motor is connected or the engine is running. It is hazardous if the motor suddenly rotates or the engine blows up.

After the linking is done, please cycle receiver power and check if the receiver to be linked is really under the control by the transmitter to be linked.

1 After installing the TM-18 RF module on the transmitter body, turn on the transmitter's power.

2 When the TM-18 LED changes from red to green, and you can confirm that it is ready for operation, press the tact switch on the TM-18 for about 3 seconds and release the tact switch when the green LED blinks once. The green LED will start blinking and will be in link mode for 30 seconds. (On the TM-18, if you press the tact switch once again during link mode, it will extend the link mode for 30 seconds from that point.)

3 Bring the receiver within 50 cm and turn on the receiver power. After turning on the receiver's power, it will be in the link waiting state about 3 seconds later.

4 The link is complete when the LED on the receiver turns from red to green. (The receiver will keep the link waiting state about 3 seconds.)

LED display of R9001SB receiver

Green	Red	Status
Off	On	No signal reception
On	Off	Receiving signals
Alternate blink		Unrecoverable error (EEPROM, etc.) If cycling the power but no recovery, please contact Futaba Service Center.

Receiver Installation

You will note that the R9001SB differs in appearance from the standard Futaba receiver.

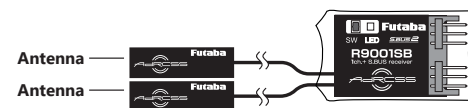

The R9001SB incorporates two separate antennas into its design, enabling it to receive radio transmission at two positions.

Futaba's dual antenna diversity, or DAD, seamlessly selects the best signal reception between these antennas to keep the solid link with the transmitter.

To obtain the best results from the R9001SB receiver, please refer to the following instructions and precautions:

1 Wrap the receiver with foam rubber to prevent it from being affected by vibrations.

2 Ensure that the two receiver antennas are kept flat. Do not fold or bend them to get best reception.

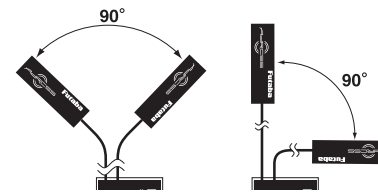

3 If possible, please ensure that the two antennas are placed 90 degrees each other. Please note: This is not a critical figure. However, the most important thing is to keep the antennas away from each other as much as possible.

4 If there are some conductive materials close to the antenna, it may degrade the quality of the RF link. Please keep the antenna away from the such materials.

5 Ensure that the antennas are at least 1/2" away from conductive materials such as metal and carbon. Please note: that this does not apply to the coaxial portion of the antenna. It is essential, however, not to bend the coax or antenna in a tight radius.

6 If the fuselage is made of conductive materials such as metal and carbon, the antenna portion MUST be positioned outside of the fuselage. Additionally, please do not attach the antenna itself to this fuselage as mentioned above #4.

* For example, many types of gliders use carbon fuselage. When installing the receiver into such models, the antenna precautions must be strictly adhered to.

WARNING

Be very careful when handling the receiver antennas. Repeated bending and flexing of the antennas or excessive force could weaken or compromise the internal antenna connections.

Keep the antennas away from the motor, ESC, and other noise sources as much as possible.

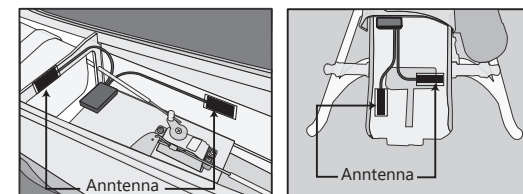

The primary purpose of the illustration is to demonstrate how the antenna should be placed. For actual installation, the receiver must be wrapped with a sponge or placed with floating material to protect it from vibration. The receiver contains delicate electronic parts and should be protected from vibration, shock, and severe temperature exposition.

* The receiver does not have a moisture-proof and waterproof function.

Once the moisture enter into the receiver, it may cause the intermittent operation or failure. Therefore, we suggest wrapping the receiver in a plastic bag or similar protective covering. This will also protect the receiver from fuel or exhaust residue that will leak into the fuselage.

Recommended use case

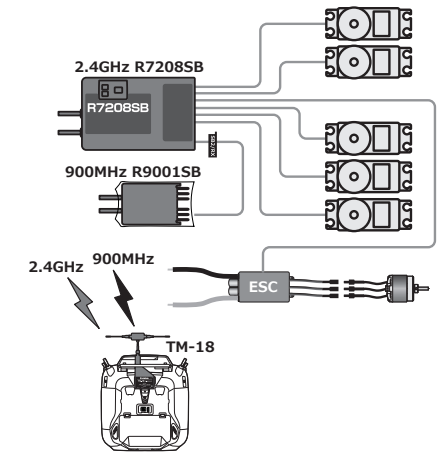

By using Futaba AdRCS 900MHz and Futaba 2.4GHz system together will provide the better secure RF link.

Setting of the F/S (Failsafe) mode

In the combination of TM-18 and R9001SB, the F/S function can be set only for the 3rd channel (throttle). For safety, we recommend using the F/S function.

F/S mode

• **HOLD:** In the signal loss, the HOLD mode holds the throttle servo in its last commanded position. (The RF output confirmation display of the transmitter usually lights.)

• **F/S:** In the signal loss, the F/S mode holds the throttle servo in its last commanded position for one second and then moves it to a predetermined position.

CAUTION

Do not press the tact SW during the flight as the module will be in range check mode so that the RF power will be lowered and will result in fatal crash.

* The TM-18+R9001SB (900MHz) can only set fail-safe for 3CH (throttle).

* Set only 3CH (throttle) for fail-safe on the 2.4GHz side.

* Set the fail-safe position of each 900MHz/2.4GHz to the same position.

Different failsafe settings may cause the servo to behave unexpectedly.

* For FDLS-1/DLPH-1, etc., it takes about 10 seconds to memorize the fail-safe position. Wait 10 seconds after turning on the power before starting the flight.

CH3 (throttle) F/S operation mode selection and F/S position setting

<HOLD ⇔ CH3-F/S mode switching method>

1 Turn on the power switch of the transmitter, and check the RF output is activated. (The LED of TM-18 will turn green from red.) Check that before powering on the receiver.

2 Move the throttle stick on the transmitter to the slow position and press the tact switch on the receiver for about 3 seconds. Release the tact switch when the LED turns off. The LED lights up red/green at the same time.

3 At this time, the HOLD mode ⇔ CH3-F/S mode is switched. When switching from HOLD mode to CH3-F/S mode, the CH3 (throttle) F/S position is set.

4 When the LED on the receiver goes from red/green simultaneous lighting to green lighting, it returns to the usual reception state.