

How to update T26SZ

Your Futaba T26SZ transmitter programming can be updated easily online. When functions are added or improved, the update file can be downloaded from our website. Copy the update files to the microSD card and then use the following procedure to update the program. Check our web site for the FAQ regarding updating for more information.

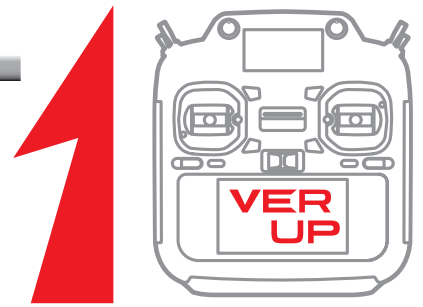

Updating procedure

Note: If the battery fully discharges during program updating, updating will fail. When the remaining battery capacity is 50% or less, always recharge the battery before updating.

Note: The model data in the transmitter can be used unchanged after updating, but to be safe, back up the model data before updating.

1. Download the zip file of the update data from our website.

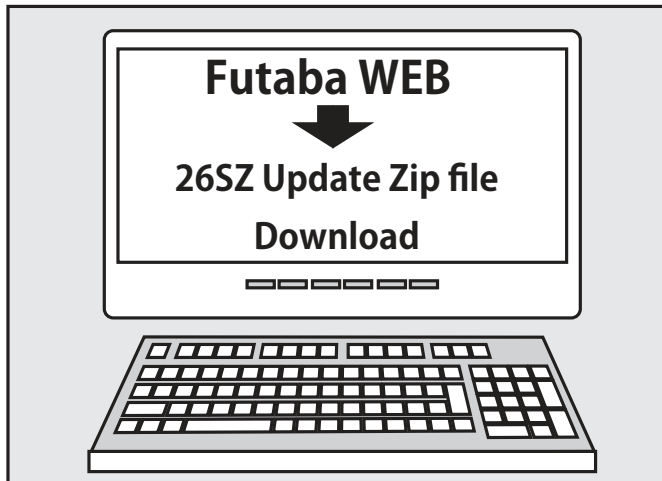

2. Extract the zip file on your computer.
3. The "FUTABA" folder will be created on your computer.
4. Copy the "FUTABA" folder into your microSD card.

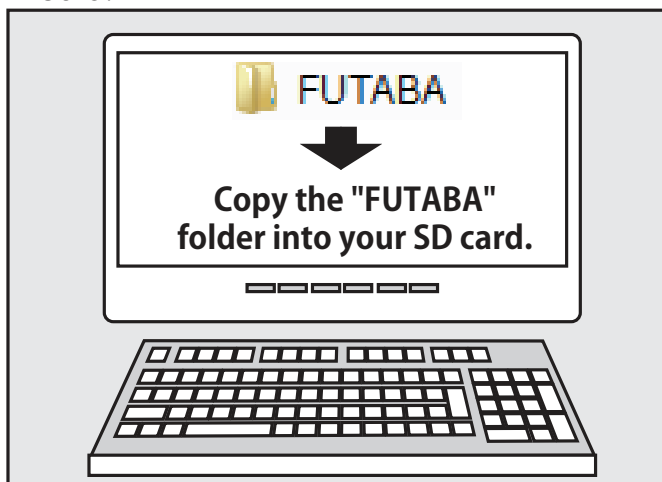

Note: If the microSD card has already had "another FUTABA" folder before you make a copy, the "FUTABA" folder is OVERWRITTEN.

5. Insert the microSD card with "FUTABA" folder that contained the update software into the SD card slot on your T26SZ radio transmitter.

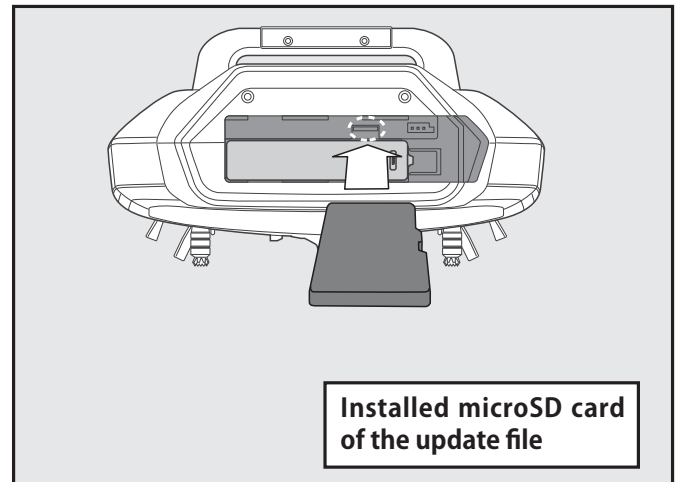

6. Turn on the transmitter power while pressing down the "EXIT" button. The update screen appears on the LCD display of your T26SZ and the software update is started.

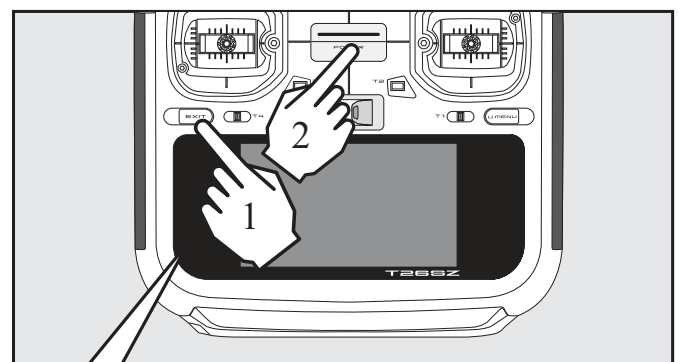

Press the EXIT switch and turn on

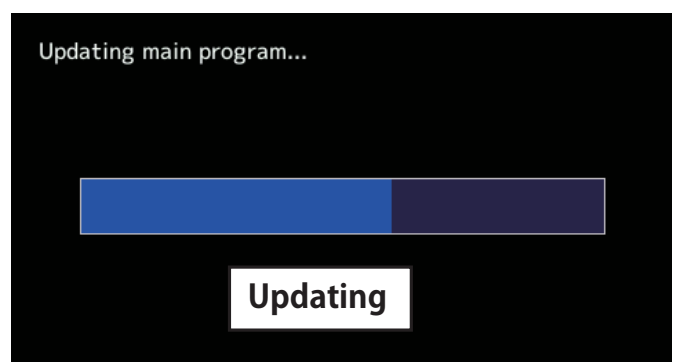

7. When the software update is completed, "Completed" message is shown on the LCD display of your T26SZ. (Show below picture.)

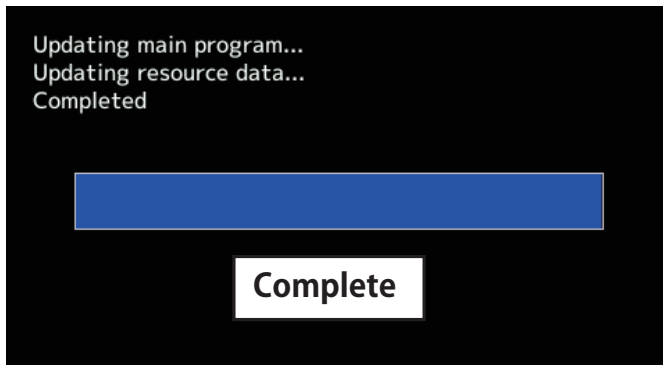

8. Turn off the power switch of your T26SZ and remove the microSD card from the card slot.

Possible Problems

When one of the error messages shown below appears on the LCD screen your T26SZ, the software update will not be completed.

"Low battery."

Software update is postponed because of low battery. Retry the software update after the battery is recharged.

"Update file not found."

The T26SZ cannot find the update file on the microSD card. Check to be sure all the update files have been copied onto the microSD card.

"Broken file."

The T26SZ detects the update file error. The update file may be broken or for another transmitter.

"Write error."

The software update procedure is stopped for an unknown reason. Contact your local service center when this error message appears on the LCD screen of your T26SZ.



Don't absolutely remove the battery and the microSD card from the transmitter during the update.

There is a possibility that the transmitter will be damaged.

Recovering a failed update

If you failed to update for any reason, it may transmitter will not start.

In that case, please update again transmitter in the following procedure.

1. Remove the battery and then reconnect it.
2. Insert the microSD card that contained the update files to the transmitter.
3. Turn on the power to the transmitter while pressing down the "EXIT" button.
4. The update will start.

Even after the above steps, if the transmitter fails to update or does not start, please have it serviced.

V7.0

This software updates or alters the functions and features noted below. The instructions and information that follow are meant as a supplement to the original instruction manual that accompanied the T26SZ transmitter. Please refer to the original instruction manual where applicable, but replace the steps indicated below with these instructions. Please check to ensure that the update has been installed.

- 1) Select the System Menu.
- 2) Touch the [Information] button.
- 3) Confirm that the information in the display indicates the version numbers as noted above.

1. The R3306GY now supports roll-flat functionality.

Roll-flat function switch settings for the R3306GY from the gyro setting screen.

*For details on the roll-flat function, refer to the R3306GY instruction manual.

- ① **Connect the R3306GY to the S.I/F connector.**

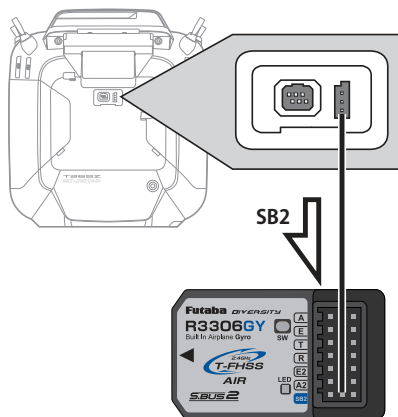

- ② **Open the [Gyro Settings] screen from the model menu and load the data.**

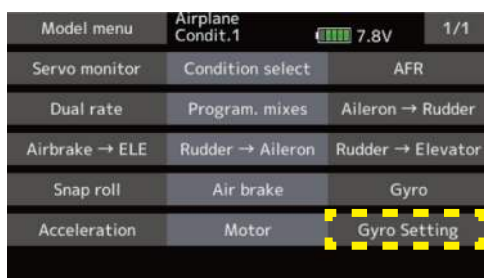

*Screen displays may vary depending on the device and settings.

- ③ **Open the [SBUS Basic] screen and set "Roll Flat SW".**

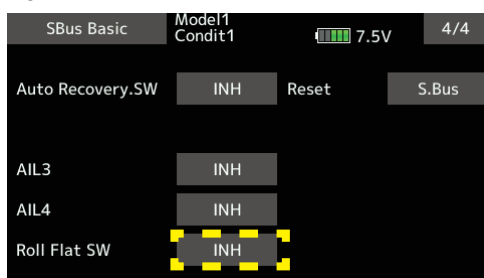

2. Updates have been added for the servos BLS-A600, HPS-A704, HPS-A703 and HPS-AA702.

Update the following servos. Refer to the servo update manual for update procedures.

- BLS-A600
- HPS-A704
- HPS-A703
- HPS-AA702

V6.1

1. Added a warning message when changing the gyro servo type.

V6.0

1. GYA483 Airplane gyro support → Refer to T26SZ(PRO)/T16IZS-GYA483 Setting manual
2. The settings for the GYA573 aircraft gyro now include a setting for the steering (RUD4) gyro function. → Refer to T26SZ(PRO)/T16IZS-GYA573 Setting manual

V5.0

1. Failsafe Delay function newly added.

By connecting a receiver that supports the failsafe delay function, can turn the fail-safe delay function ON/OFF.

This function enables the servo movement softly toward the preset failsafe position when the failsafe activated.

Also when back to normal operation the servo movement softly back to the position of under controlled.

To enable this function, please go to Receiver Setting menu in the "System Menu" of the transmitter.

This delay function is valid for all channels set failsafe and not able to set each channel independently.

※ This function is valid for Battery Failsafe as well.

The receivers that support the failsafe delay function are as follows:

*The firmware update of the correspond receivers is necessary to use this function.

Receiver	Supported Versions
R7208SB R7308SB	V2.3~
R7206SB R7306SB	V1.3~
R7214SB R7314SB	V1.3~
R7201SB R7301SB	V1.4~

1. Connect the receiver's S.BUS2 port to the transmitter's S.I/F port with the receiver setting/update cable.
2. Tap [Receiver setting] on the [System menu]
3. Tap [Read]
4. Select ON/OFF for the Failsafe delay function.

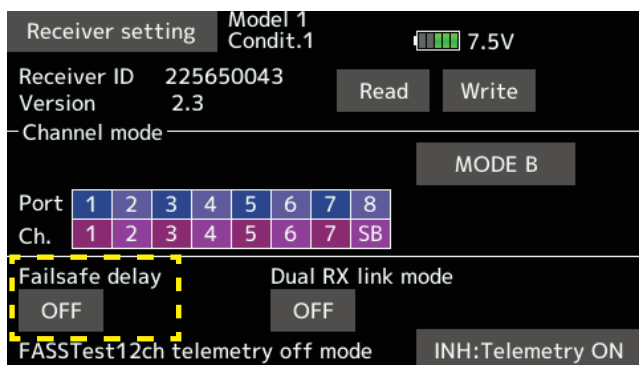

*If you connect a receiver that does not support the failsafe delay function, you will not be able to operate the failsafe delay setting button.
Update your receiver to the latest version.

5. Tap [Write]
6. Remove the receiver.

V4.0

1. GYA573 Ver.6.x New firmware support → Refer to T26SZ/T16IZS-GYA573 V.6.x Setting manual

Added Vector Nozzle function for jet models.

Camber mixing setting rate has been expanded from ± 100 to ± 200 .

2. Supports the telemetry function of the O.S.ENGINE ECU EC-24/EC-23.

3. Now compatible with Power Hub DLPH-3.

By connecting the DLPH-3 to the transmitter, it is possible to change the mode of the DLPH-3.

- ① Connect the DLPH-3 to the transmitter as shown.

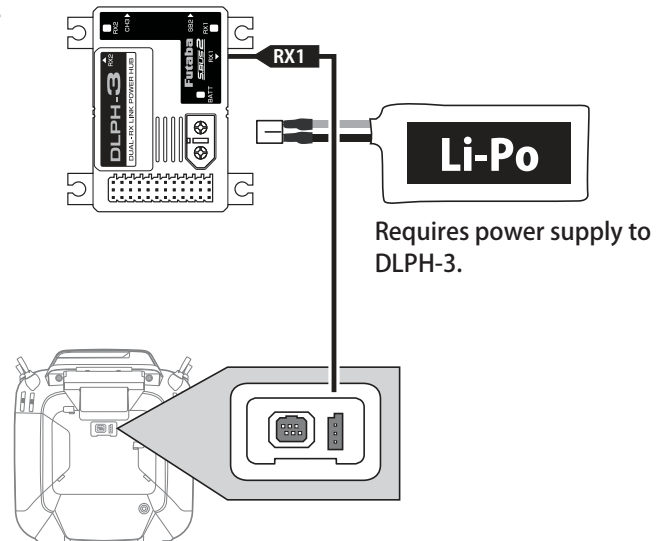

- ② Call up the System Menu → DLPH screen.

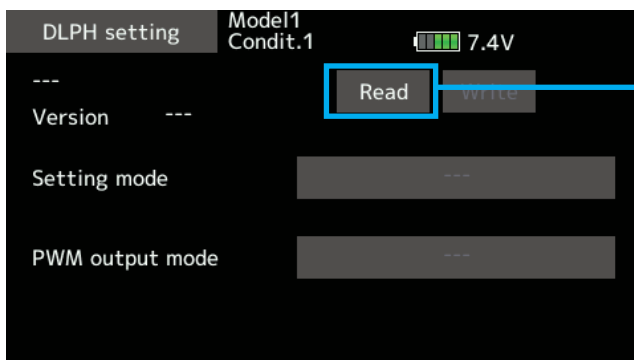
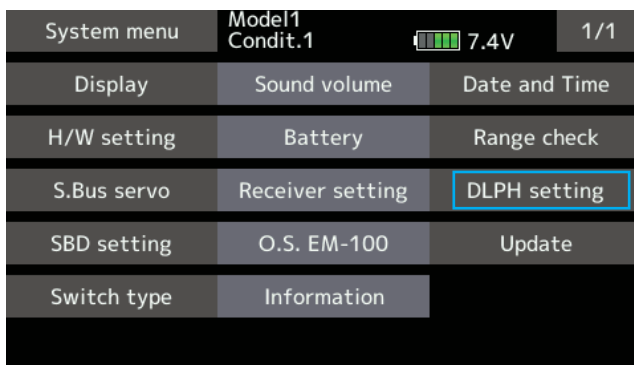

- ③ Tap [Read].

④ The version of the connected DLPH-3 is displayed.

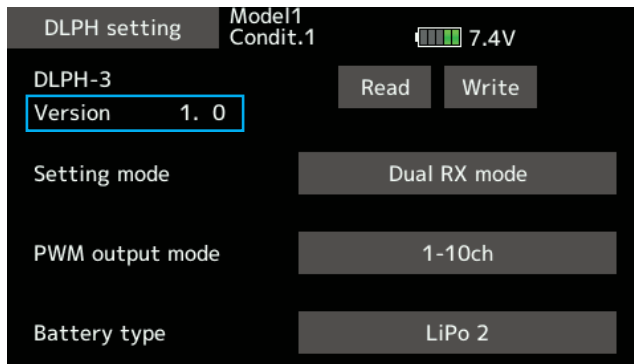

If reading fails, the above message will be displayed. Check the connection.

⑤ Set the mode of the DLPH-3.

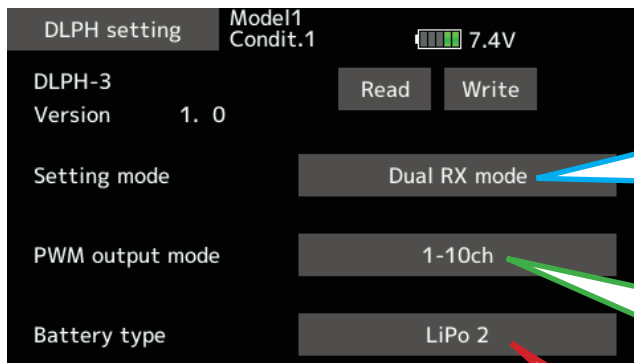

Tapping the Setting mode switches as follows:
[Dual Rx mode] → [Single Rx mode] →
[Airplane Gyro] → [Dual Rx mode] → ...

Tapping the PWM output mode switches as follows:
[1-10ch] → [11-20ch] → [21-24ch] → [1-10ch] → ...

Tapping the Battery type switches as follows:
[LiPo 2] → [LiFe 2] → [LiPo 3] → [LiPo 2] → ...

⑥ Tap Write, a confirmation screen will appear. Tap "Yes" to write the settings to the DLPH-3.

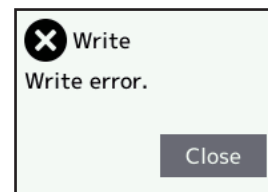
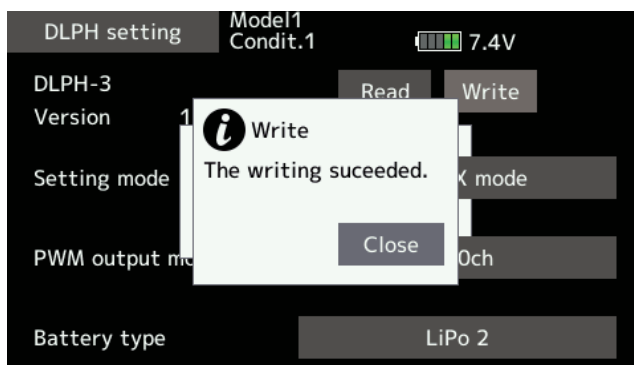

If writing fails, the above message will be displayed. Check the connection.

V3.0

1. GYA573 New firmware support. → Refer to T26SZ/T16IZ SUPER GYA573 Setting manual

V2.0

1. EC-22/EC-21 telemetry function added

Supports the telemetry function of the O.S.ENGINE ECU EC-22/EC-21.

2. Sound switch, voice notification German language support

The sound switch function and voice notification function now support German. (German version only)

V1.3

The following corrections have been made to the CGY760R and CGY770R gyro settings.

1. Fixed a bug where the output servo signal would jitter severely when changing the servo type in the RUD basic menu.
2. Fixed a bug in the reset values of SWH Basic's Pitch High, Pitch Zero, and Pitch Low.
3. Removed the blank page in S.BUS Basic for CGY760R/CGY755.
4. Corrected the AUX.CH servo type setting value after performing a reset of the S.BUS Basic for CGY770R.

V1.2

1. Fixed the telemetry speech of SBS-01ML.
2. The display of the third-party telemetry product "GPS-F1675" has been corrected.
3. The display of the side lever (RST) has been corrected.